

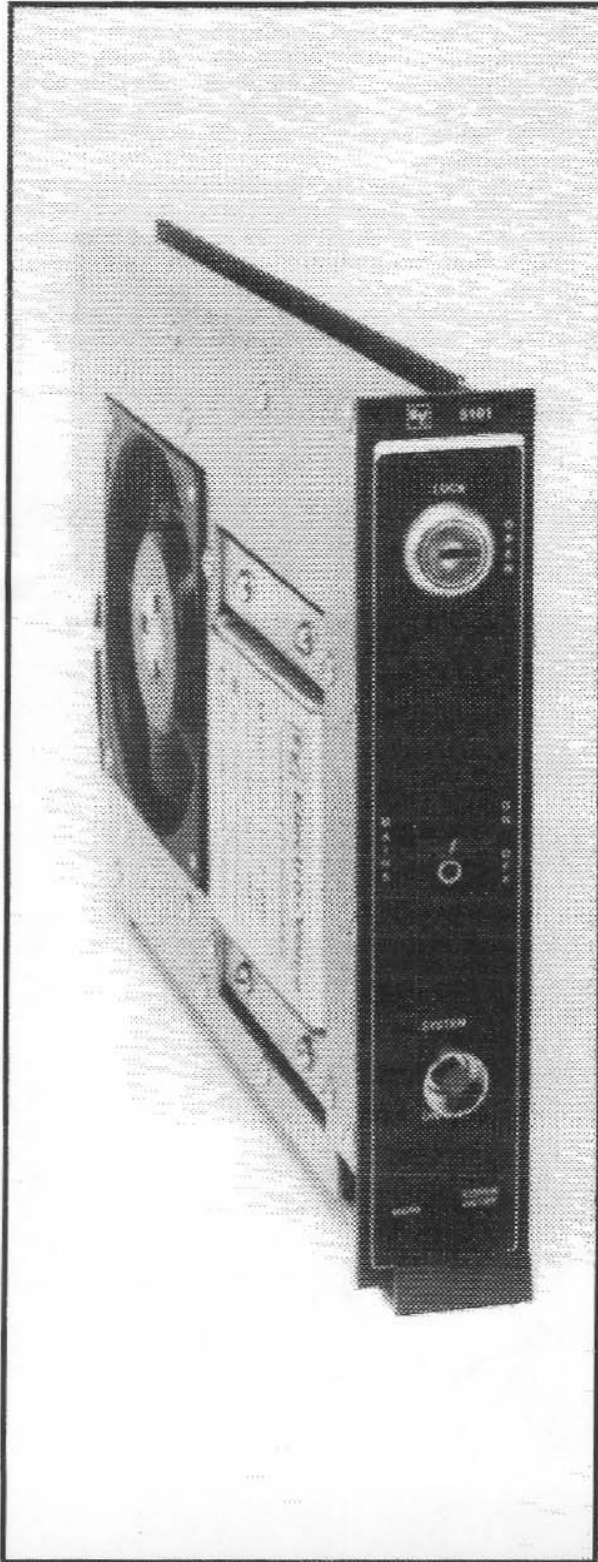

## 5101 Power Module

## 5000 Modular System



- Master ac on/off switch
- System on/off status memory
- 110/220V selection
- On/off status memory
- LED status indicators
- Remote on/off capability
- 2 speed fan
- Front panel keylock

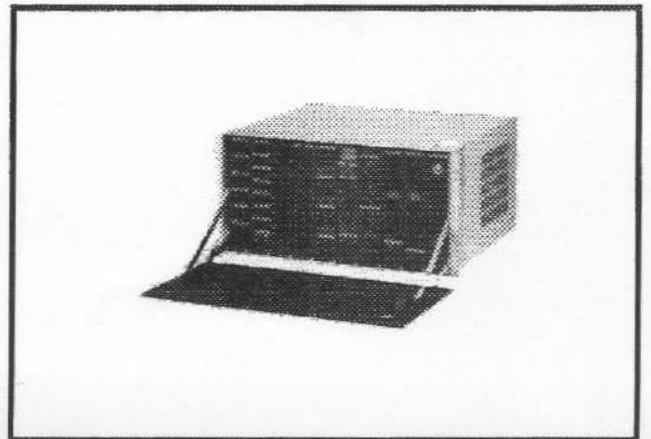



# 5101 Power Module

The 5101 power module provides ac power distribution and fan cooling to all other modules within the series 5000 mainframe. Contained within the module is the control circuitry for 115/220 VAC switching, system master fuse protection, and remote controlled turn on and turn off of the entire system.

Competitive modular sound systems typically use a single large power supply capable of delivering power for a maximally loaded system. As a result you are forced to pay for a very expensive power supply even though your system configuration may not require the maximum available power. Further, the entire system must rely on one single power source. Any malfunction in the power unit will cause failure of the entire system.

All modules of the 5000 system contain their own dc power supplies, providing total redundancy of operation and reliability. Economy is not sacrificed, because you pay only for the power required by that particular system configuration. Also, an added advantage of the power-supply-per-module concept is that the supply voltages can be optimized for each module. This feature allows the acoustic engineer to use 8-ohm amplifiers and 50-ohm/70-volt amplifiers in the mainframe simultaneously, even though the power supply requirements are totally different.

A triac switching circuit in the 5101 controls the flow of ac power to all the signal processing modules within the mainframe. The triac switch can be activated using the front panel controls or via remote controlled switches (requires low-current dc). Additional remote on/off switches can be paralleled as desired. The triac switch system has a memory so that if power should fail, the triac will remain in the same ON, or OFF state as at the time of the power failure.

After the triac is gated ON, the ac power will then flow to the 115/220-volt switch. This switch selects the proper wiring configuration for all transformer primaries within the mainframe. The ac is then distributed to the mother board in the mainframe for use by the modules. The ac power is then fused, rectified, filtered, and regulated in each individual module.

A two-speed fan is also incorporated in the 5101. This fan provides forced air cooling for all amplifier modules and is thermostatically controlled by the amplifier modules.

The power supply design of the 5101 system offers a new level of reliability and flexibility to the acoustic engineer.

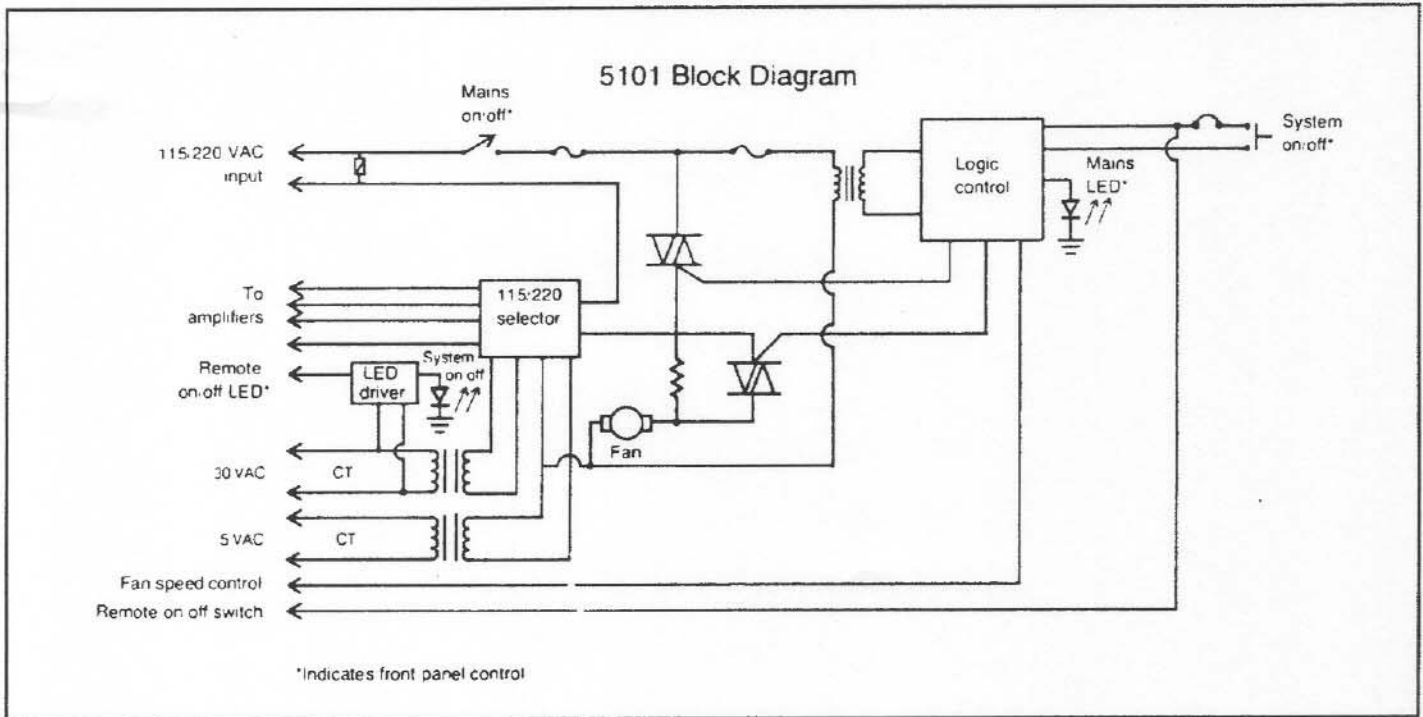

## 5101 Spec Briefs

- Input voltage: 100-130 VAC  
200-260 VAC
- Frequency: 50-60 Hz
- Power consumption: 1725 watts max
- Fan cooling: 2-speed
- Size: 8.5x14.2x1.7 inches
- Weight: 8 lbs.

**For Warranty and Service Information consult the Owner's Manual.**

## Electro-Voice, Inc.

a Mark IV company  
600 Cecil Street  
Buchanan, MI 49107  
(616) 695-6831 FAX (616) 695-1304



## 5202 2-Way Crossover

## 5000 Modular System

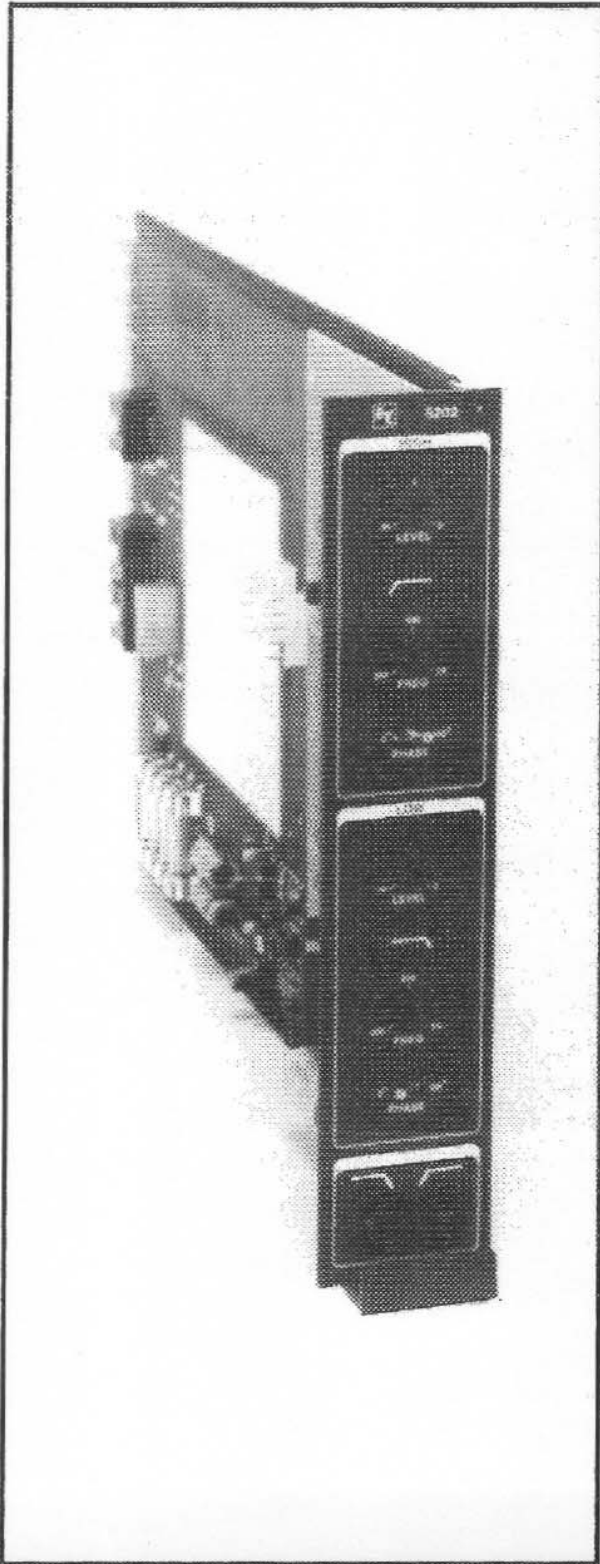

- Continuously variable crossover points. 200 Hz to 2 kHz
  - Independent adjustment of high- and low-pass crossover point
  - Switchable crossover slopes (12 or 18 dB/octave)
  - Individually selectable slopes for high- and low-pass filters (12 or 18 dB/octave)
  - Optional equalization for HF drivers and Thiele-tuned LF enclosures
  - Phase reversal switch
  - Test points for real time analyzer
  - Signal output indicators
- Optional security cover available

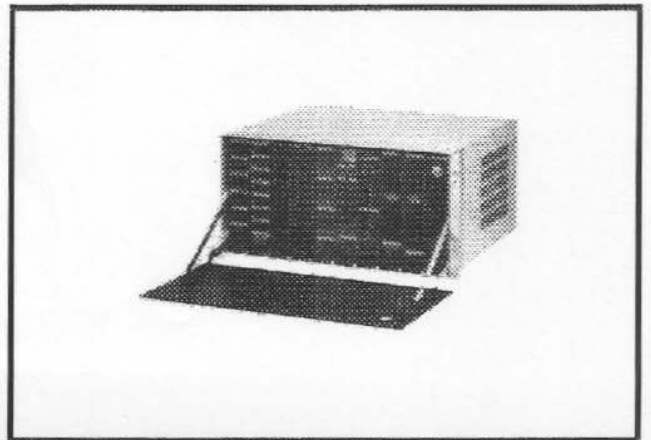



# 5202 2-Way Crossover

In selecting crossovers for the wide variety of transducers available today, one can no longer assume that the best possible sound may be achieved by using the standard crossover points of 500 or 800 Hz. It is also improper to assume that both the low-frequency and high-frequency transducers should crossover with the same slope or that their crossover points should be exactly at the  $-3$  dB point.

In fact, the crossover plays a very vital role in the overall sonic performance of the system. Depending upon the changing polar response vs. frequency of low-frequency transducers, it may be desirable to roll-off the low-frequency speaker at the rate of only 12 dB per octave. But in order to protect a high-frequency compression driver, it may be desirable to roll it off at a rate of 18 dB per octave. The crossover points would then need to be independently adjustable in order to provide a flat overall response. For convenience it would also be desirable to control the polarity or phasing ( $0^\circ$ - $180^\circ$ ) at the crossover in order to facilitate setup. Also, certain low-frequency drivers require additional equalization at the extremes of their frequency response limits.

The 5202 two-way crossover will fulfill all of the above requirements and offer several additional features. The 5202 is comprised of two independently adjustable filter sections. The low- and high-pass filters have identical features and controls, and are adjustable from 200 Hz to 2 kHz. An output

level control is located directly above each frequency control. The polarity of the filter output may be inverted in order to match the polarity of the transducers in use.

The two front panel LEDs indicate the presence of an output signal from each filter. The LED will vary in intensity with the output signal from that particular filter.

The two front panel test points are connected to the audio output of each filter and provide easy access to the filter for monitoring the crossover point and roll off slope with a real time analyzer. The test points also facilitate access to the audio buss for documentation or troubleshooting of the system.

On the inside of the 5202, a 12/18 dB-per-octave roll-off switch is provided for each filter. The audio input and output buss assign switches are located at the rear of the module.

There are two gold-plated connectors on the inside of the 5202. These connectors will accept additional low-frequency and high-frequency equalizer circuit boards. The low frequency circuit board will provide equalization for low-frequency enclosures utilizing Thiele tuned technology. The high frequency circuit board will provide the high frequency boost.

The 5202 is a versatile two-way crossover with the features required to satisfy the demanding requirements of today's professional sound reinforcement systems.

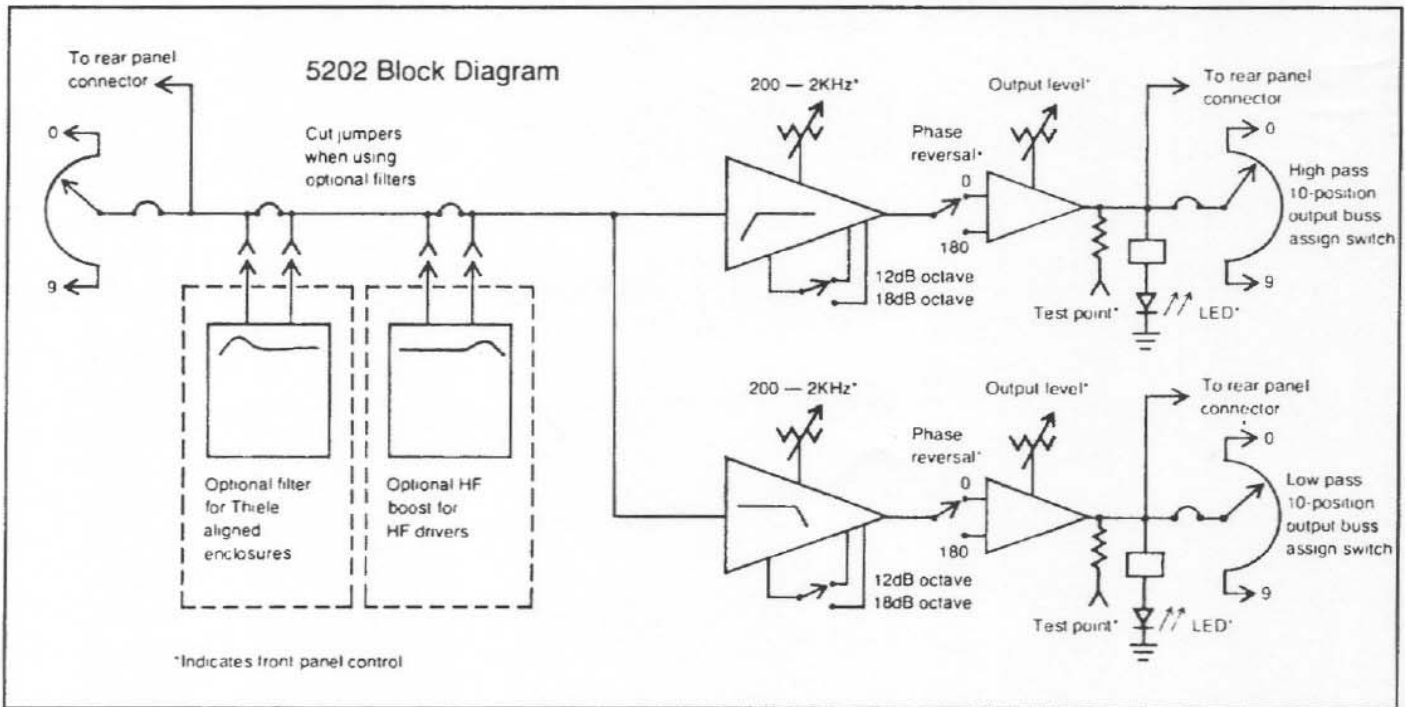

## 5202 Spec Briefs

Maximum input level: +20 dBm  
 Input Impedance: 10,000 ohms  
 Output level: +18 dBm  
 Output load impedance:  
 600 ohms or greater  
 Gain: Unity

Crossover frequency: 200 Hz-2 kHz  
 Filters: separate 12/18 dB octave Butterworth  
 Size: 8.5x14.2x1.7 inches  
 Weight: 1 lb. 4 oz.  
 THD less than .01% @ +18 dBm  
 Noise: -90 dBm 35 kHz bandwidth

**For Warranty and Service Information consult the Owner's Manual.**

Form 2870 • ©Electro-Voice, Inc. 1989 • Litho in U.S.A.

**Electro-Voice, Inc.**

a Mark IV company  
 600 Cecil Street  
 Buchanan, MI 49107  
 (616) 695-6831 FAX (616) 695-1304





## 5301 Octave-Band Equalizer

## 5000 Modular System

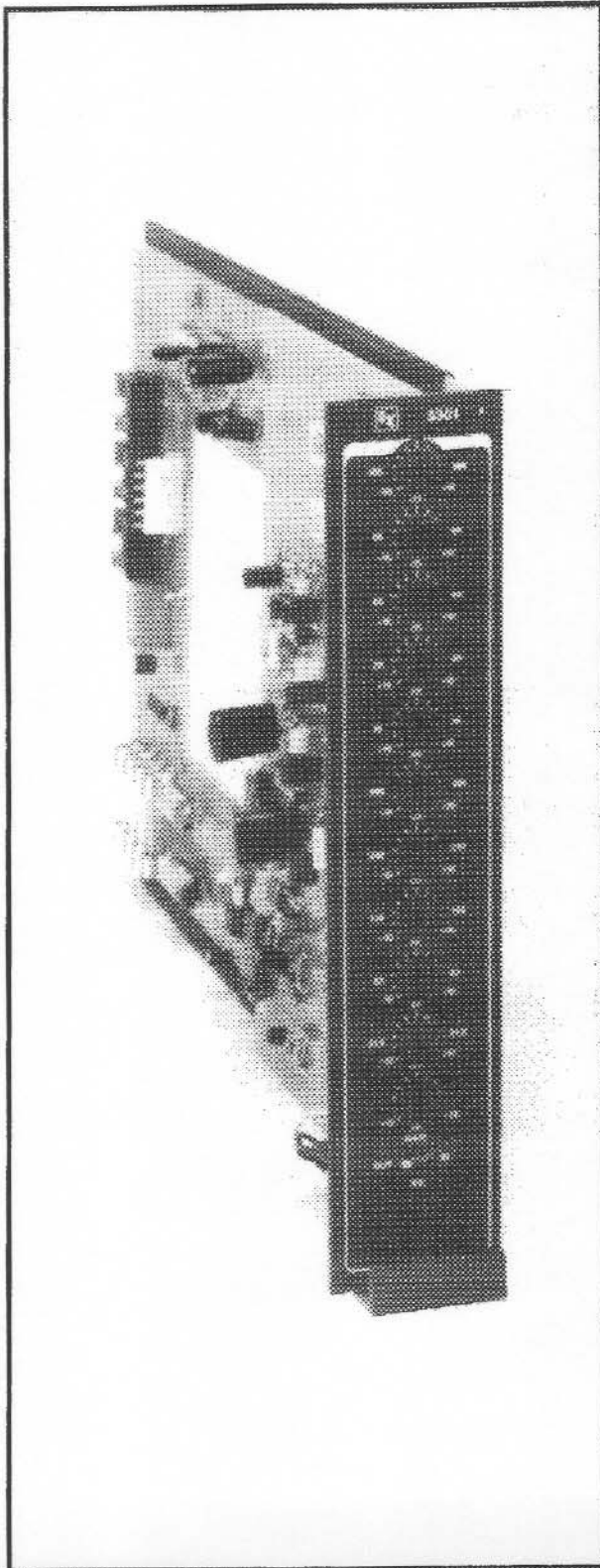

- 10 filters on ISO standard octave-band centers
- Covers audio spectrum 31.5 Hz-16,000 Hz
- All filters combine for maximum performance
- 4-position high-pass filter
- 10 dB boost or cut on each filter
- EQ in/out switch (hardware bypass on EQ out position)
- Front panel gain control
- On board accessory socket to accept low level crossover network
- Optional security cover available
- LED signal output and EQ bypass indicator
- Front panel audio test point
- Optional remote EQ in/out

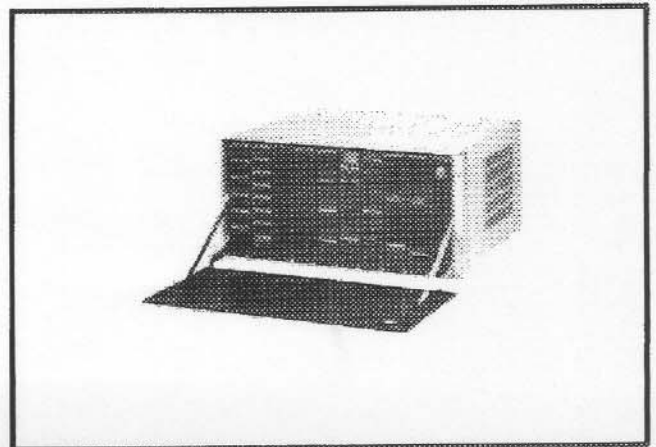



5301

The 5301 contains 10 filters on ISO standard octave-band centers ranging from 31.5 Hz to 16 Hz. Each filter section provides 10 dB of boost or cut. The 10 filters are active, minimum phase networks whose skirts combine to produce minimum ripple and phase shift. An EQ IN/OUT switch allows before and after equalization comparisons. A separate level control permits compensation for gain changes during the equalization process.

A front panel LED serves the dual purpose of signal presence indicator, and an EQ bypass indicator. With the EQ IN/OUT switch in the OUT position, the LED flashes on and off at the rate of 3 Hz to indicate the EQ is being bypassed. With the EQ IN/OUT switch in the IN position, the LED is activated by the audio signal, varying in intensity according to the amplitude of the audio signal, thus providing positive indication of output from the 5301.

An audio test point, connected to the output of the equalizer, is located on the front of the 5301. This test point allows the output of the equalizer to be viewed with an oscilloscope, real time analyzer, or ac volt meter. This provides convenient system troubleshooting and documentation.

The optional plug in crossover cards are user programmable to the desired crossover frequency. The user programs the plug-in cards by soldering the proper value resistor onto the plug-in cards. A crossover frequency vs. resistance chart is provided to aid the user in determining the proper resistor values. This provides the greatest flexibility while maintaining an economical alternative to the 5202 crossover module.

Installation of the crossover cards requires cutting one PC board jumper wire, and plugging the crossover board onto the 5301 board. These cards, when used in conjunction with the 5301 equalizer, provide economical signal processing for your system.

Located inside the 5301 is an 18 dB/octave high-pass filter with four switch-selectable roll-off frequencies. The -3 dB down points are 40, 80 and 160 Hz.

The 5301 is a professional octave-band equalizer designed for use in the most demanding sound reinforcement system. The 5301 and its optional crossover cards provide equalization and filtering at a reasonable price.

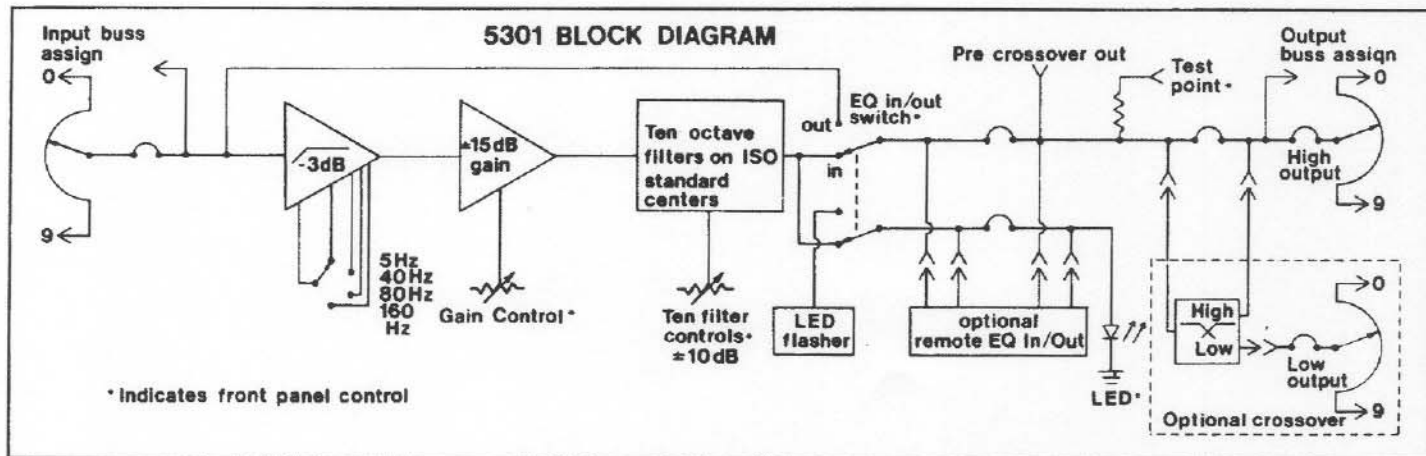

**5301 Spec Briefs**

Maximum input level: 20 dBm  
Input impedance: 10,000 ohms  
Output level: +18 dBm  
Output load impedance: 600 ohms or greater  
Available gain: -15 to +15 dB  
THD: .01% at +18 dBm  
Noise: -92 dBm 35 kHz bandwidth  
Frequency accuracy: 5% of center frequency

Filters: 10 active combining filters on ISO standard center with ±10 dB of boost and cut  
High-pass filter: 18 dB/octave roll off, switch selectable at "flat," 40, 80 and 160 Hz  
Size: 8.5x14.2x1.7 inches  
Weight: 2 lbs

**For Warranty and Service Information consult the Owner's Manual.**

Form 2878 • ©Electro-Voice, Inc. 1989 • Litho in U.S.A.

**Electro-Voice, Inc.**

a Mark IV company  
600 Cecil Street  
Buchanan, MI 49107  
(616) 695-6831 FAX (616) 695-1304



## 5303 1/3-Octave Equalizer

## 5000 Modular System

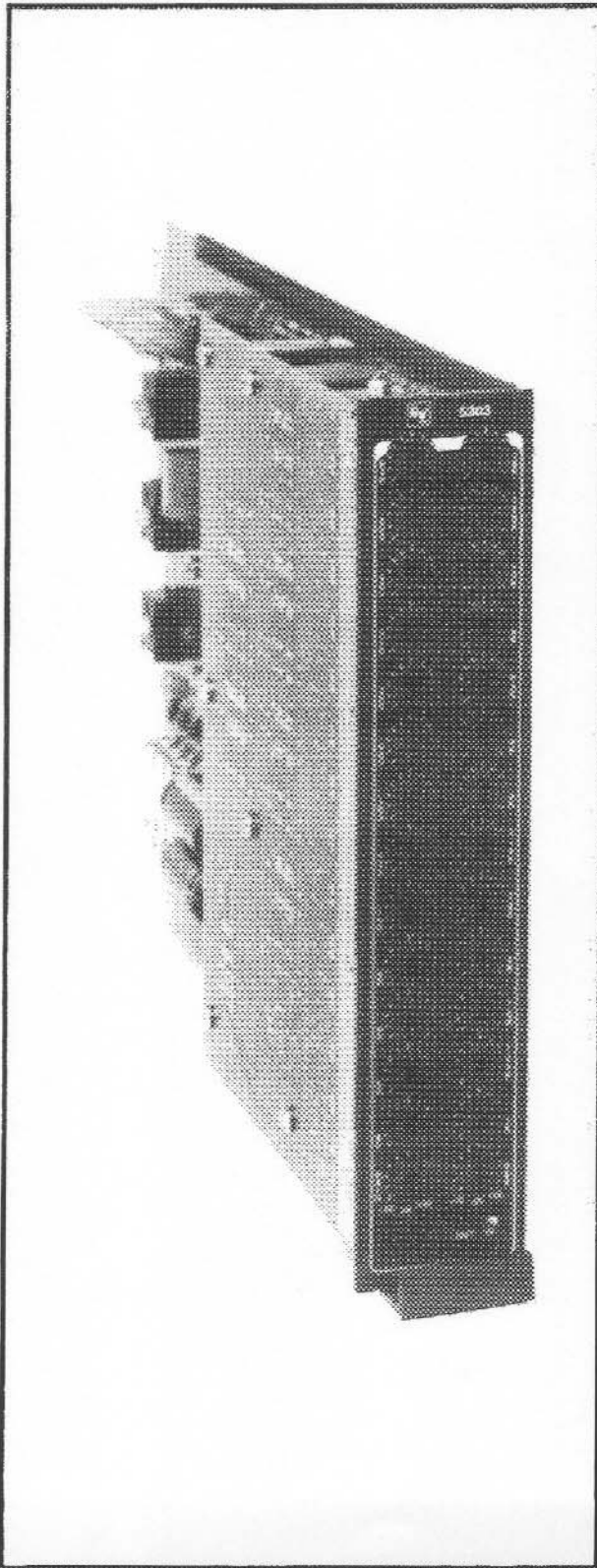

- 27 filters on ISO standard 1/3-octave centers
- Covers audio spectrum 40 Hz-16,000 Hz
- All filters combine for maximum performance
- 4-position high pass filter
- 10 dB boost or cut on each filter
- EQ in/out switch (hardware bypass on EQ out position)
- Front panel gain control
- On board accessory socket to accept low level crossover network
- Optional security cover available
- LED signal output and EQ bypass indicator
- Front panel audio test point
- Optional remote EQ in/out

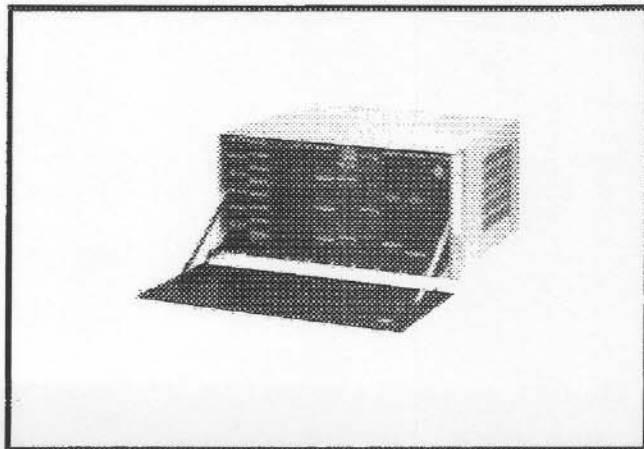



# 5303 1/3-Octave Equalizer

The model 5303 is a state-of-the-art 1/3-octave, active equalizer designed to provide accurate, flexible equalization of professional audio systems. Design parameters assure maximum signal to noise ratio, and circuit stability.

The 5303 contains 27 filters on ISO standard 1/3-octave centers ranging from 40 Hz to 16 kHz. Each filter section provides 10 dB of boost or cut. The 27 filters are active, minimum phase networks whose skirts combine to produce minimum ripple and phase shift. An EQ in/out switch allows before and after equalization comparisons. A separate level control permits compensations for gain changes during the equalization process.

A front panel LED serves the dual purpose of signal presence indicator, and an EQ bypass indicator. With the EQ in/out switch in the "out" position, the LED flashes on and off at the rate of 3 Hz to indicate the EQ is being bypassed. With the EQ in/out switch in the "in" position, the LED is activated by the audio signal, varying in intensity according to the amplitude of the audio signal, thus providing positive indication of output from the 5303.

An audio test point, connected to the output of the equalizer, is located on the front panel of the 5303. This test point allows the output of the equalizer to be viewed with an oscilloscope, real time analyzer, or ac volt meter. This provides convenient system troubleshooting and documentation.

The 5303 has provisions to accept optional plug in crossover cards. The crossover cards provide two outputs, one high pass and one low pass from the 5303 equalizer.

The optional plug in crossover cards will be user programmable to the desired crossover frequency. The user will program the plug in cards by soldering the proper value resistor onto the plug-in cards. A crossover frequency vs. resistance chart will be provided to aid the user in determining the proper resistor values. This provides the greatest flexibility while maintaining an economical alternative to the 5202 crossover module.

Installation of the crossover cards requires cutting one PC board jumper wire and plugging on the crossover board.

These cards when used in conjunction with the 5303 equalizer provide economical signal processing for your system. Located inside the 5303 is a high pass filter with four switch-selectable roll off frequencies. The -3 dB roll off points are 5, 40, 80, and 160 Hz.

The 5303 is a professional 1/3-octave equalizer designed for use in the most demanding sound reinforcement system. The 5303 and its optional crossover cards provide equalization and filtering at a reasonable price.

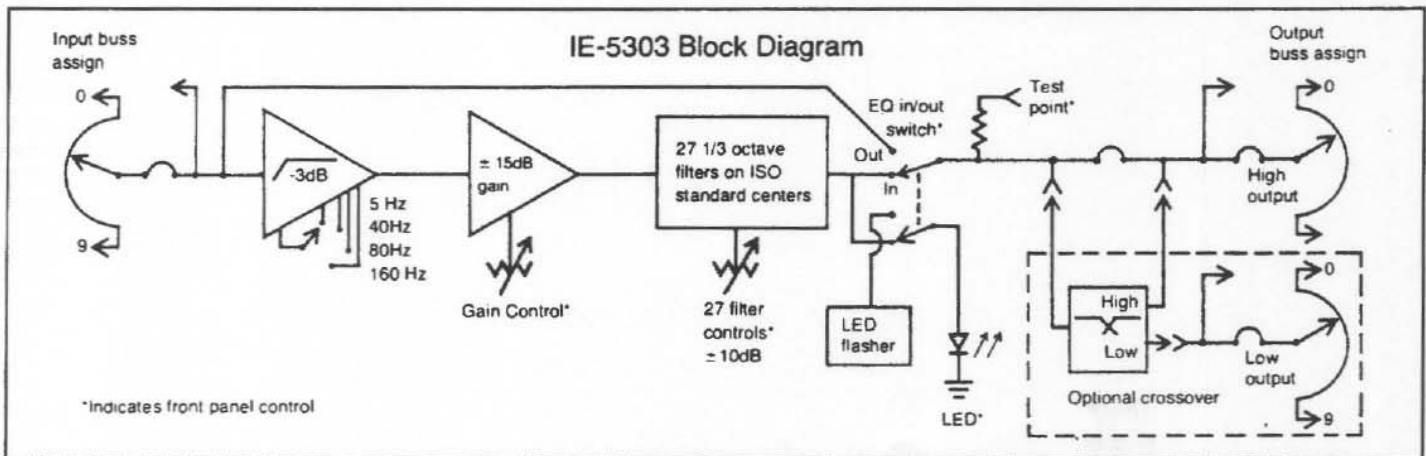

## 5303 Spec Briefs

Maximum input level: 20 dBm  
Input impedance: 10,000 ohms  
Output level: +18 dBm  
Output load impedance: 600 ohms or greater  
Available gain: -15 to +15 dB  
THD: .01% @ +18 dBm  
Noise: -90 dBm 35 kHz bandwidth  
Frequency accuracy: 3% of center frequency

Filters: 27 active combining filters on ISO standard center with ±10 dBm of boost and cut  
High pass filter: 18 dB/octave roll off, switch selectable @ 4, 40, 80 and 160 Hz  
Size: 8.5x14.2x1.7 inches  
Weight: 2 lbs.





## 5306 Notch Filter

## 5000 Modular System

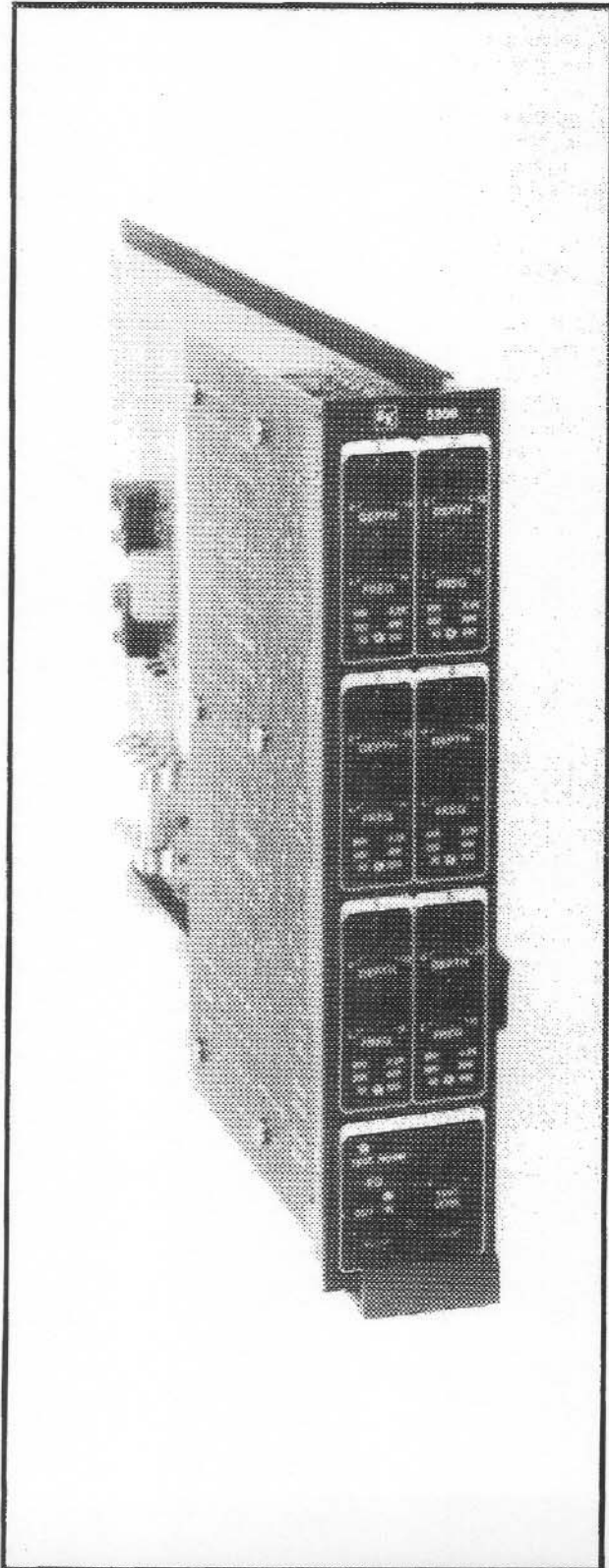

- Excellent for feedback suppression
- 6 tunable  $\frac{1}{10}$ -octave notch filters
- Each filter independently adjustable
- Variable notch depth 0 to 12 dB
- Tuning range 50 Hz to 3.2 kHz
- Temperature drift compensated
- EQ in/out switch (hardware bypass in EQ out position)
- Compressor to sustain feedback during tuning
- Front panel filter tuning test point
- Front panel audio test point
- LED signal output and EQ bypass
- Optional security cover available

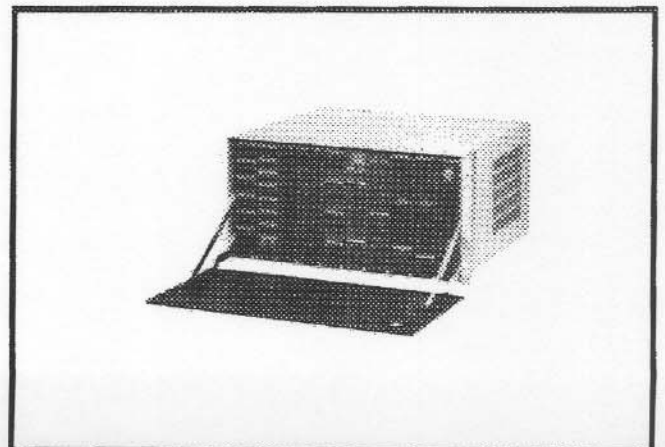



The 5306 is a set of six tunable notch filters—an excellent tool for reducing feedback. The 5306 makes possible the precise removal of feedback frequencies without adversely affecting the desired equalization curve. This allows greater sound levels to be achieved in the room before the sound system squeals or begins to feedback. An increase in intelligibility may also be noticed.

The 5306 may be used to complement existing octave or 1/3-octave sound system equalization. In smaller sound systems the 5306 may be used by itself to increase gain before feedback. In addition to reducing feedback the 5306 may also be employed to reduce microphone proximity effects and annoying room resonances.

The 5306 is comprised of six tunable 1/10-octave band reject filters; each is adjustable from 50 Hz to 3.2 kHz. The frequency range is divided into three bands, thus providing high resolution and ease in tuning.

Tuning of the filter is easily and accurately accomplished with the aid of an ac voltmeter (pocket VOM etc.) or real time analyzer. The 5306 filters may also be accurately tuned by ear.

There are several features on the 5306 that aid in the tuning of its filters. A NORMAL/TEST switch when placed in the test position inserts a compressor in line with the filters. The compression level is controlled by the test gain control on the front panel of the 5306. The compressor sustains and controls the feedback level in the room. Once feedback is sustained

in the room the filter frequency range is selected and the output voltage on the test point is monitored with any test instrument capable of measuring 0 to 1 volt ac. The filter is then tuned for maximum voltage on the test point. This will center the filter on the feedback frequency. The notch depth control is then turned on until the feedback note disappears. The process is then repeated for the remaining filters. After tuning is complete the NORMAL/TEST switch is returned to the normal position.

The 5306 contains an equalizer IN/OUT switch allowing bypassing of the 5306 for comparison purposes. The LED on the front panel serves two functions, 1) it is an output signal presence indicator and will vary in brightness with the audio signal appearing at the output of the 5306, 2) when the notch filter EQ IN/OUT switch is in the OUT position, the LED will flash on and off at the rate of 3 Hz as a reminder that the filter is bypassed.

A second test point located on the 5306 front panel is connected to the output of the 5306. This test point allows the use of oscilloscopes, real time analyzers, ac volt meters, etc. for system documentation and troubleshooting.

The 5306 is a powerful signal processor that will allow you to easily remove undesired feedback frequencies and increase the overall gain before feedback of any sound system.

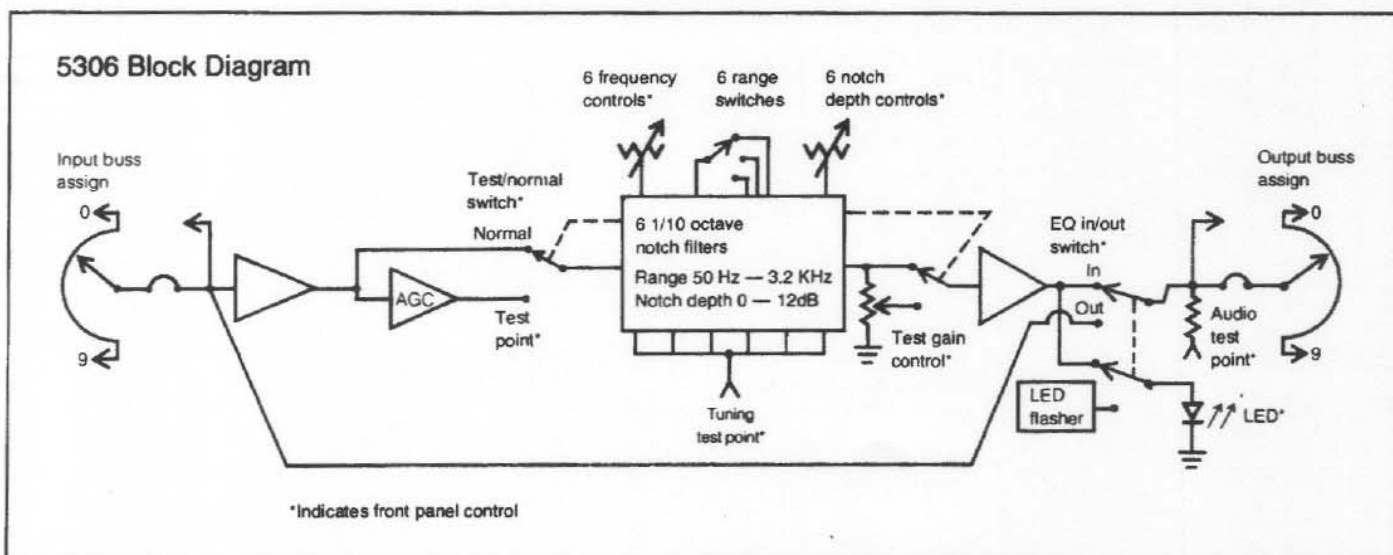

#### 5306 Spec Briefs

Maximum input level: +20 dBm  
 Input impedance: 10,000 ohms  
 Output level: +18 dBm  
 Output load impedance: 600 ohms or greater  
 Gain: unity  
 THD: .01% at +18 dBm

Noise: -80 dBm, 35 kHz bandwidth  
 Filter bandwidth: 1/10 octave  
 Filter tuning range: 50-3200 Hz  
 Notch depth: 0-12 dB  
 Size: 8.5x14.2x1.7 inches  
 Weight: 1 lb, 5 oz.

**For Warranty and Service information consult the Owner's Manual.**

Form 2882 • ©Electro-Voice, Inc. 1989 • Litho in U.S.A.

**Electro-Voice, Inc.**

a Mark IV company  
 600 Cecil Street  
 Buchanan, MI 49107  
 (616) 695-6831 FAX (616) 695-1304



## 5502 Automatic Microphone Mixer

## 5000 Modular System

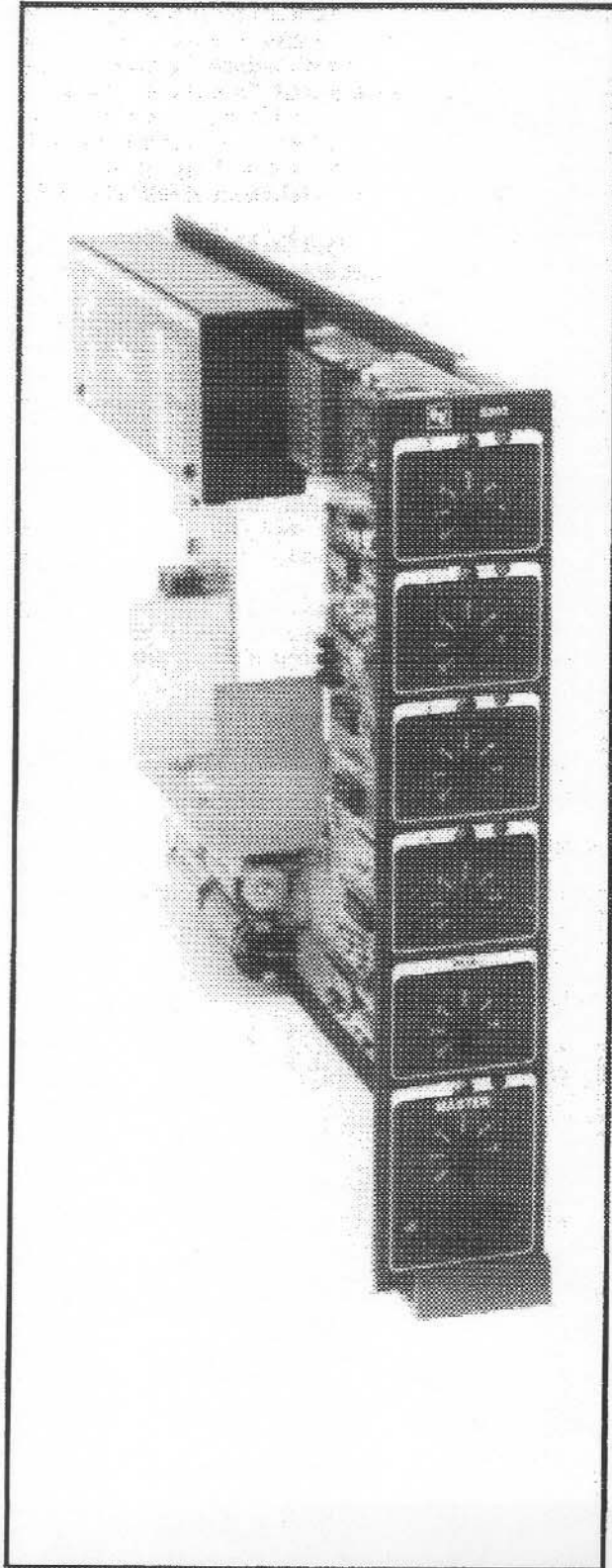

- Automatic gating with NOM attenuation
- Designed specifically for room combining applications
- VCA override or mute for life safety paging
- 4 transformer-balanced microphone/line inputs
- 1 unbalanced auxiliary line level input
- Separate input for background music
- Separate input for paging
- Adjustable "off" attenuation on each channel
- Adjustable release time
- Direct channel outputs—pre and post gate
- Remote control of master level
- Remote On/Off control of all inputs
- "Channel active" indication on front panel
- Status output port for "channel active"
- Pre-gate tape output

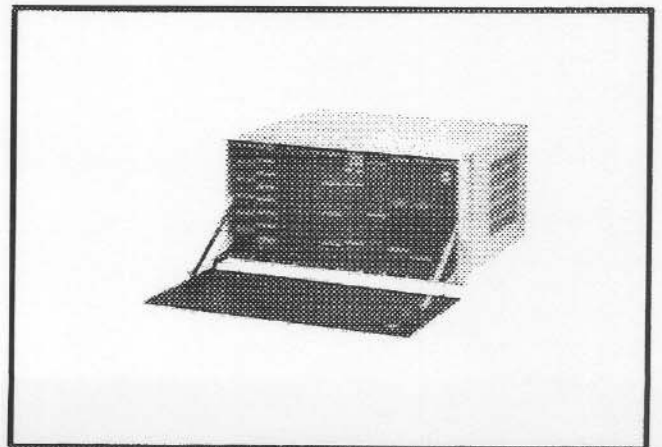



# 5502 Automatic Microphone Mixer

**NEW BREED** The 5502 is a new breed of automatic microphone mixer designed to meet the ever changing requirements of the professional sound reinforcement industry. Its unique combination of features provide many benefits for the consultant, contractor and end user. These features make this mixer ideal for use in meeting rooms, churches, and teleconferencing. These standard features provide the consultant with powerful tools that allow the increased flexibility of design necessary to meet the needs of the end user, while still allowing for ease of installation by the contractor without the need for custom work.

**SEVEN INPUTS** The 5502 has seven inputs, five of them controllable from the front panel. These five inputs include four switchable (mic/line) transformer balanced, automatic gating inputs and one non-gating, unbalanced auxiliary line input.

The sixth and seventh inputs are special. One input is specifically intended for background music applications. It is a fixed gain, 50 k ohm, unbalanced, line level input, with remote on/off capability. The 50 k input impedance allows over 80 mixers to be driven from a 600-ohm source. A remote on/off background music switch can be located wherever desired. The seventh input is designed with paging in mind. It is a fixed gain, 50 k input impedance, with remote on/off capability. It can be mixed with the other channels either before or after the master volume control. When mixed after the volume control, all other signals may be completely muted, or simply "ducked," during the page. This feature was designed with "Life Safety" type applications in mind.

**ROOM COMBINING** One of the applications the 5502 is specifically designed to fulfill, is that of combining sound systems in multiple meeting

rooms. For example: A hotel has a complex of eight meeting rooms of various sizes. At times all meeting rooms are used independently of one another, while at other times moveable partitions between rooms are opened, to create one large room. Of course, any combination of rooms can also occur. The 5502 can be combined with other 5502's to effect room combining. A complete line of room combining accessories greatly enhance the power of the 5502 automatic mixer. When 5502's are combined, all automatic functions such as NOM and THRESHOLD are also combined.

**"LAST ON"??** The 5502 has a feature called "Last On." This is an optional feature and is activated by installing a wire jumper on the terminal board used with the mixer. So what exactly does the "Last On" function do? Very simply, the last microphone that was gated on automatically, remains on until another microphone is gated on to take its place. This means that at least one microphone is always on in the room. This has many benefits in recording meetings or in teleconferencing. "Last On" will allow several microphones to be on at the same time, if dictated by microphone usage.

**FEATURES-FEATURES-FEATURES** The 5502 can be ganged with other 5502's to provide a greater number of inputs, when required. Each channel has adjustable "Off" attenuation, channel active status indicator, and an open-collector status output port. The 5502 has too many features to allow a detailed discussion of each one. We therefore invite you to contact your local Electro-Voice representative or the factory, for a copy of the 5502 owner's and operator's manual. This manual contains detailed information on the many features of the 5502 and how to apply them.

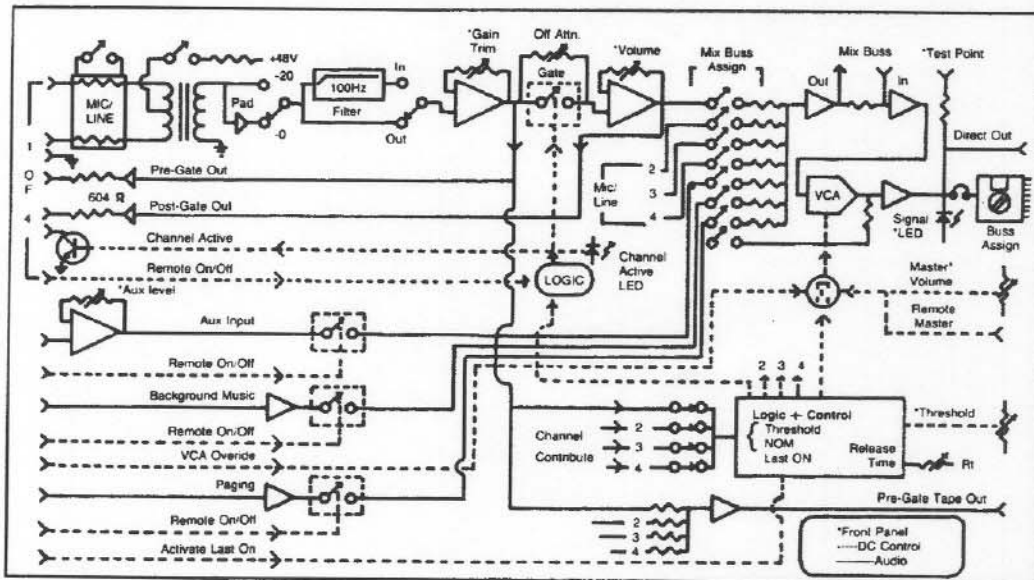

## 5502 Spec Briefs

Frequency response: -5 dB 20 Hz to 20 kHz  
 Distortion THD: .01%  
 Maximum gain: 83 dB  
 Microphone input impedance: 150-600 ohms  
 transformer balanced  
 Line input impedance: 30,000 ohms  
 transformer balanced

Output load impedance: 600 ohms or greater  
 Maximum output level: +18 dBm  
 Channel off attenuation: 0 to -100 dB  
 Channel release time: .1 to 10 sec.  
 Channel direct output impedance: 600 ohms

**For Warranty and Service Information consult the Owner's Manual.**

Form 2871 • ©Electro-Voice, Inc. 1989 • Litho in U.S.A.

**Electro-Voice, Inc.**

a Mark IV company  
 600 Cecil Street  
 Buchanan, MI 49107

(616) 695-6831 FAX (616) 695-1304





## 5503 Automatic Microphone Mixer with Remote Control

5000  
Modular System

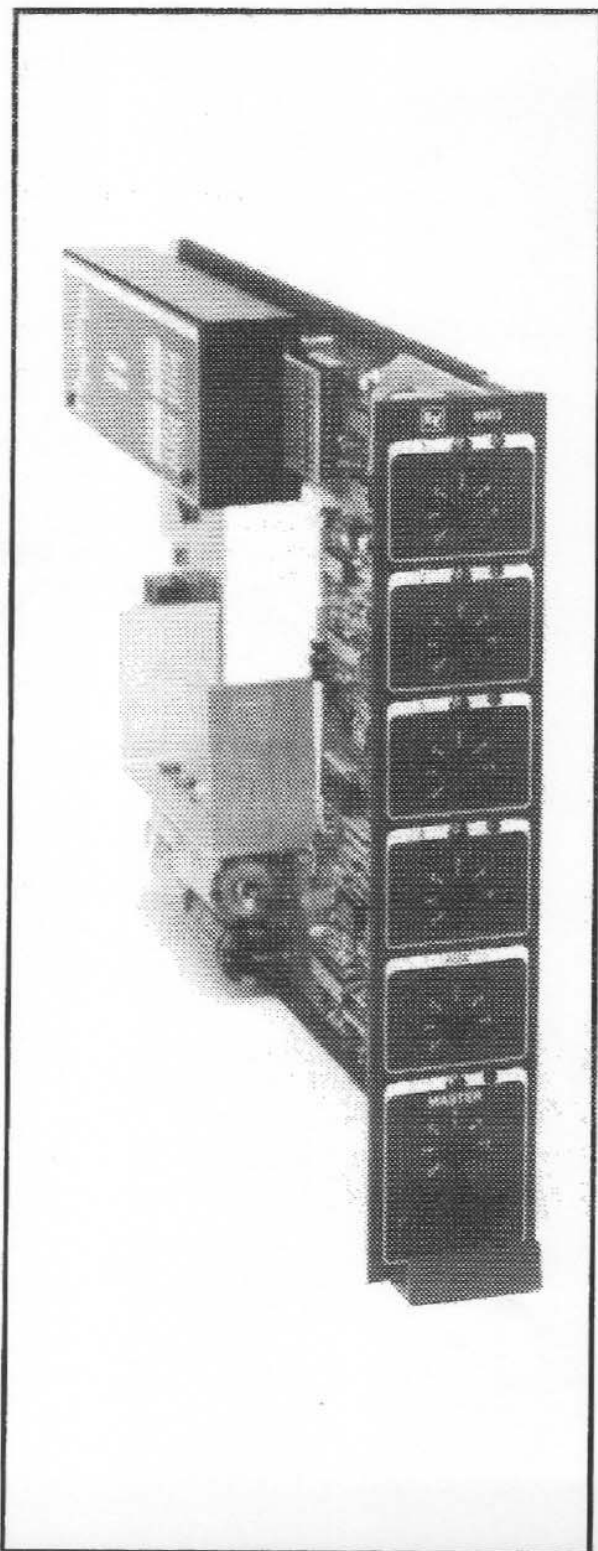

- Automatic gating with NOM attenuation
- Designed specifically for room combining applications
- VCA override or mute for emergency paging
- 4 transformer-balanced microphone/line inputs
- 1 unbalanced auxiliary line level input
- Separate input for background music
- Separate input for paging
- Adjustable "off" attenuation on each channel
- Adjustable release time
- Direct channel outputs—pre and post gate
- Remote control of master level
- Remote On/Off control of all inputs
- "Channel active" indication on front panel
- Status output port for "channel active"
- Pre-gate tape output

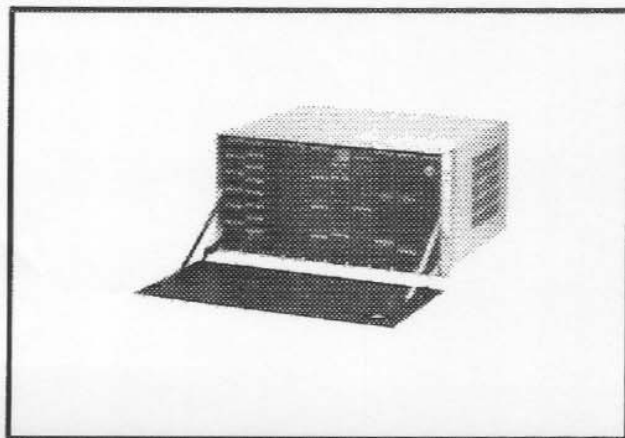



# 5503 Automatic Microphone Mixer with Remote Control

**NEW BREED** The 5503 is a new breed of automatic microphone mixer designed to meet the ever changing requirements of the professional sound reinforcement industry. Its unique combination of features provide many benefits for the consultant, contractor and end user. These features make this mixer ideal for use in meeting rooms, churches, and teleconferencing. These standard features provide the consultant with powerful tools that allow the increased flexibility of design necessary to meet the needs of the end user, while still allowing for ease of installation by the contractor without the need for custom work. The 5503 has all the features of the 5502 with the addition of remote control of all front panel controls.

**SEVEN INPUTS** The 5503 has seven inputs, five of them controllable from the front panel. These five inputs include four switchable (mic/line) transformer balanced, automatic gating inputs and one non-gating, unbalanced auxiliary line input.

The sixth and seventh inputs are special. One input is specifically intended for background music applications. It is a fixed gain, 50 k ohm, unbalanced, line level input, with remote on/off capability. The 50 k input impedance allows over 80 mixers to be driven from a single 600-ohm source. A remote on/off background music switch can be located wherever desired. The seventh input is designed with paging in mind. It is a fixed gain, 50 k input impedance, with remote on/off capability. It can be mixed with the other channels either before or after the master volume control. When mixed after the volume control, all other signals may be completely muted, or simply "ducked," during the page. This feature was designed with emergency paging applications in mind.

**ROOM COMBINING** One of the applications the 5503 is specifically

designed to fulfill, is that of combining sound systems in multiple meeting rooms. For example: A hotel has a complex of eight meeting rooms of various sizes. At times all meeting rooms are used independently of one another, while at other times moveable partitions between rooms are opened, to create one large room. Of course, any combination of rooms can also occur. The 5503 can be combined with other 5503's to effect room combining. A complete line of room combining accessories greatly enhance the power of the 5503 automatic mixer. When 5503's are combined, all automatic functions such as NOM and THRESHOLD are also combined.

**"LAST ON"??** The 5503 has a feature called "Last On." This feature may be activated by installing a wire jumper on the terminal board used with the mixer. So what exactly does the "Last On" function do? Very simply; the last microphone that was gated on automatically, remains on until another microphone is gated on to take its place. This means that at least one microphone is always on in the room. This has many benefits in recording meetings or in teleconferencing. "Last On" will allow several microphones to be on at the same time, if dictated by microphone usage.

**FEATURES-FEATURES-FEATURES** The 5503 can be ganged with other 5503's to provide a greater number of inputs, when required. Each channel has adjustable "Off" attenuation, channel active status indicator, and an open-collector status output port. The 5503 has too many features to allow a detailed discussion of each one. We therefore invite you to request a copy of the 5503 owner's and operator's manual. This manual contains detailed information on the many features of the 5503 and how to apply them.

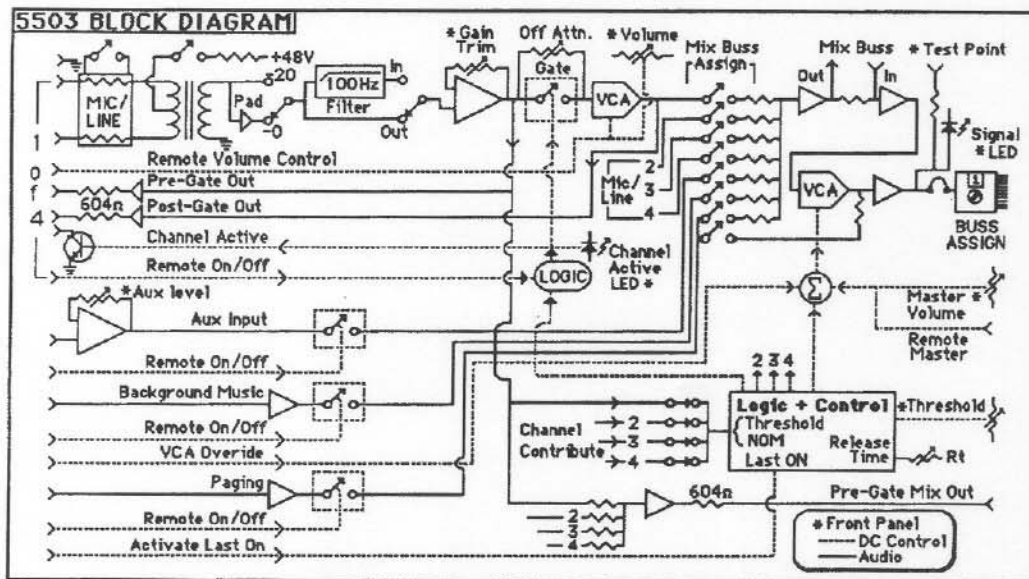

## 5503 Spec Briefs

Frequency response:  $\pm 0.5$  dB 20 Hz to 20 kHz  
 Distortion THD: Less than 0.1%  
 Mic input Z: 150-600 ohms  
 Line input Z: 30,000 ohms  
 Output load Z: 600 ohms or greater  
 Maximum output level: +18 dBm  
 Channel off attenuation: 0 to 90 dB  
 Maximum gain: 83 dB

For Warranty and Service Information consult the Owner's Manual.

Form 2872 • ©Electro-Voice, Inc. 1989 • Litho in U.S.A.

Electro-Voice, Inc.

a Mark IV company

600 Cecil Street

Buchanan, MI 49107

(616) 695-6831 FAX (616) 695-1304



**5505  
6x1 Mixer**

**5000  
Modular System**

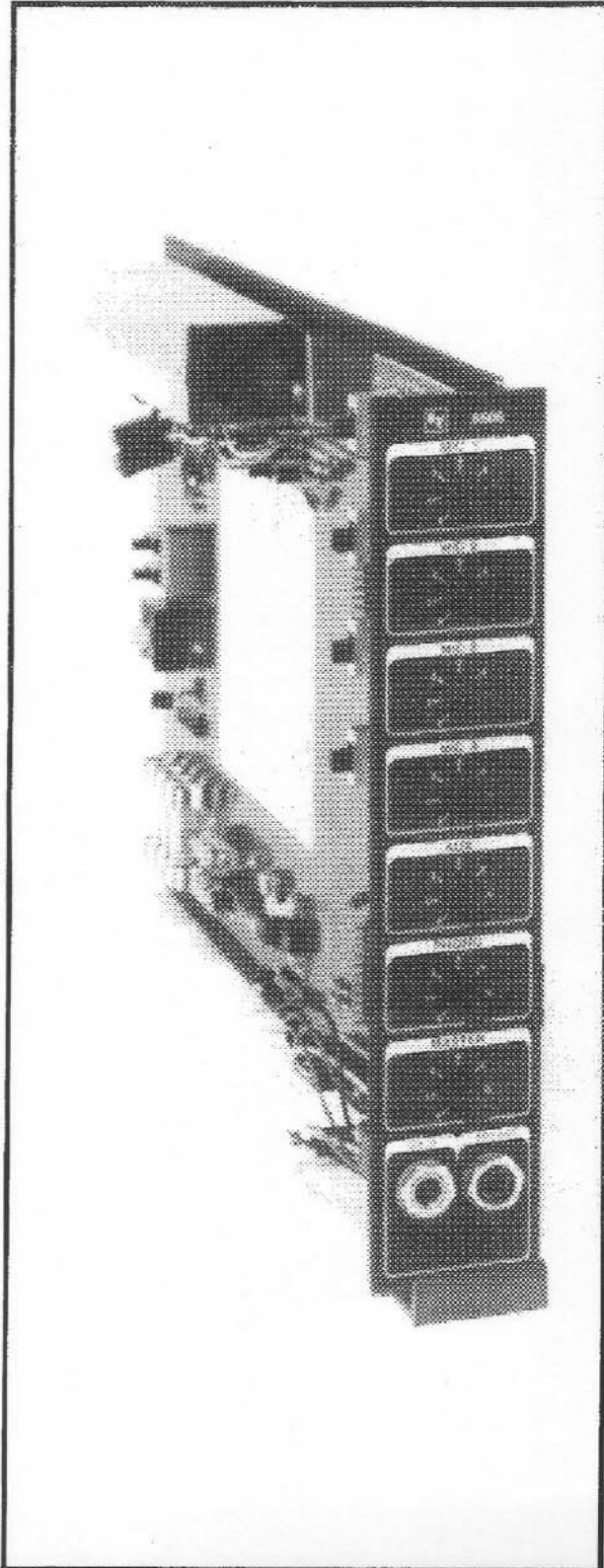

- 4 low-Z mic inputs, transformer balanced
- 1 aux line-level input
- 1 RIAA stereo magnetic phono input
- 1 master output control
- 20 dB switchable pad on each mic input
- Phantom power available on each mic input
- Switchable low-frequency cut-off filter on each mic input
- Buffered tape output
- Direct mic out (prefader) on each input
- LED signal presence indicator
- Front panel audio test point
- May be ganged with other mixers
- Optional security cover available

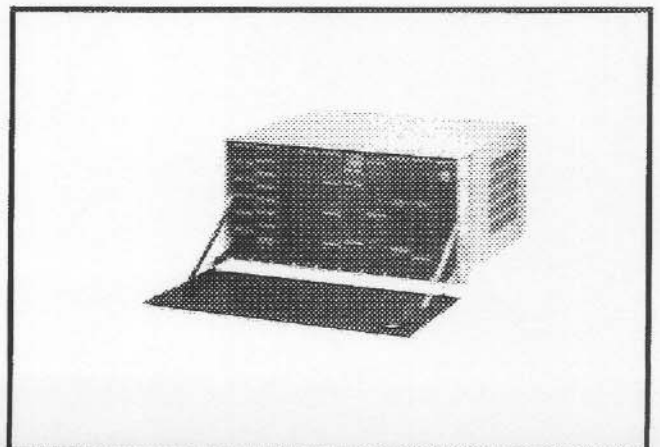



# 5505

## 6x1 Mixer

of 4 transformer-balanced microphone inputs, 1 unbalanced auxiliary line level input, and 1 stereo magnetic phono input.

Each microphone input has a switchable low-cut filter designed to reduce "P-pop" type noises or other unwanted low-frequency noise. The response of the filter is 6-dB-down at 125 Hz and 32-dB-down at 60 Hz. Phantom power is also available on each of the four inputs along with a switchable 20-dB pad.

The auxiliary line level input appears both on the rear panel TB40 and on the front panel. The input is "normaled through" the front panel 1/4-inch phone jack to the rear panel TB40. The TB40 input is disconnected when a 1/4-inch phone plug is inserted in the front-panel jack.

The 6th input is a stereo magnetic phono cartridge input. The left and right channels are electronically combined to mono and then properly equalized following the RIAA standard.

channels of mixing capability is desired. For example, two buses gang-ed together would provide 12 inputs and 2 isolated outputs.

Each of the 4 microphones has a prefader direct output accessible on the TB40. As an example of use, these outputs could possibly be sent directly to a recording or monitor mixer. There is also a buffered tape output available which comes before the master control that appears on both the rear TB40 and at a 1/4-inch phone jack mounted for easy access on the front panel.

In addition to the front panel level controls, AUX IN and TAPE OUT connectors, the 5505 mixer has all the usual 5000 features including the front panel test point and the LED signal indicator.

When there is a requirement for a basic low-cost mixer or sub-mixer, the EV 5505 is an important addition to the modular system.

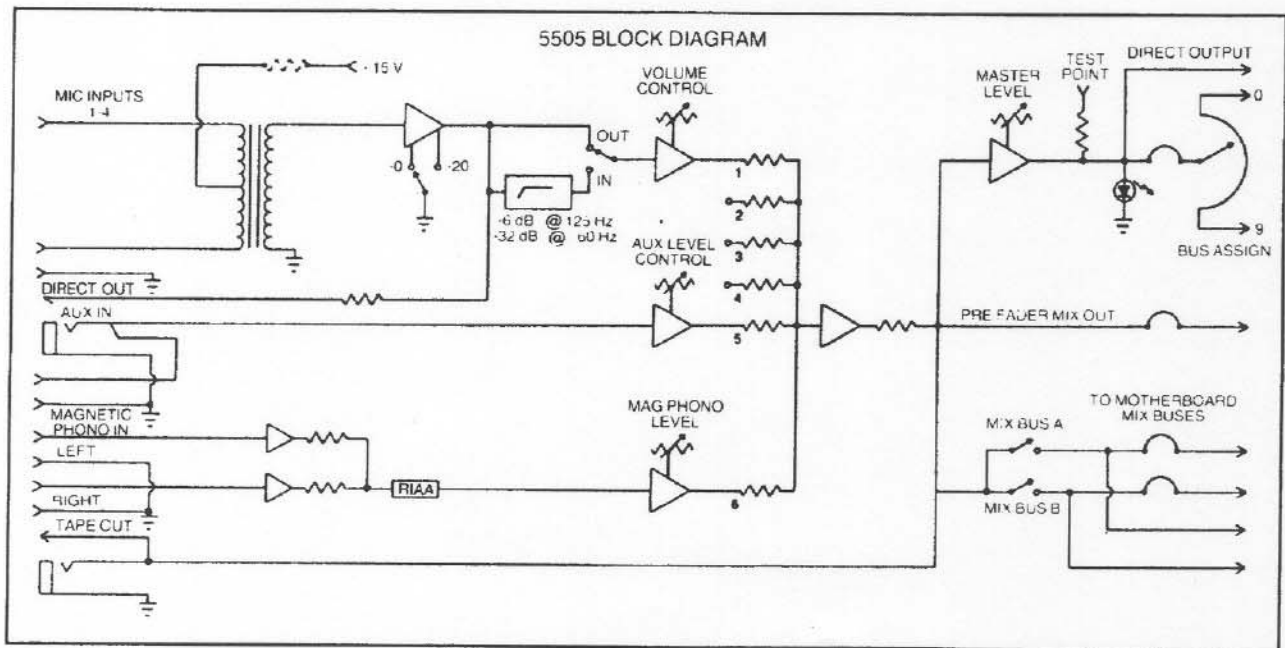

### 5505 Spec Briefs

Microphone input impedance: 150-600 ohms  
 Frequency response: 20 Hz-20 kHz  $\pm$  5 dB  
 Input noise: -126 dBm A weight  
 THD: .01% typical  
 Auxiliary line input impedance: 100,000 ohms  
 Magnetic phono input impedance:  
 47,000 ohms

Output load impedance: 600 ohms or greater  
 Output level: 18 dBm  
 High-pass filter: -6 dB at 125 Hz,  
 -32 dB at 60 Hz  
 Size: 8.5x14.2x1.7 inches  
 Weight: 2 lbs

**For Warranty and Service Information consult the Owner's Manual.**

Form 2880 • ©Electro-Voice, Inc. 1989 • Litho in U.S.A.

## Electro-Voice, Inc.

a Mark IV company

600 Cecil Street

Buchanan, MI 49107

(616) 695-6831 FAX (616) 695-1304





## 5506 6x2 Mixer

## 5000 Modular System

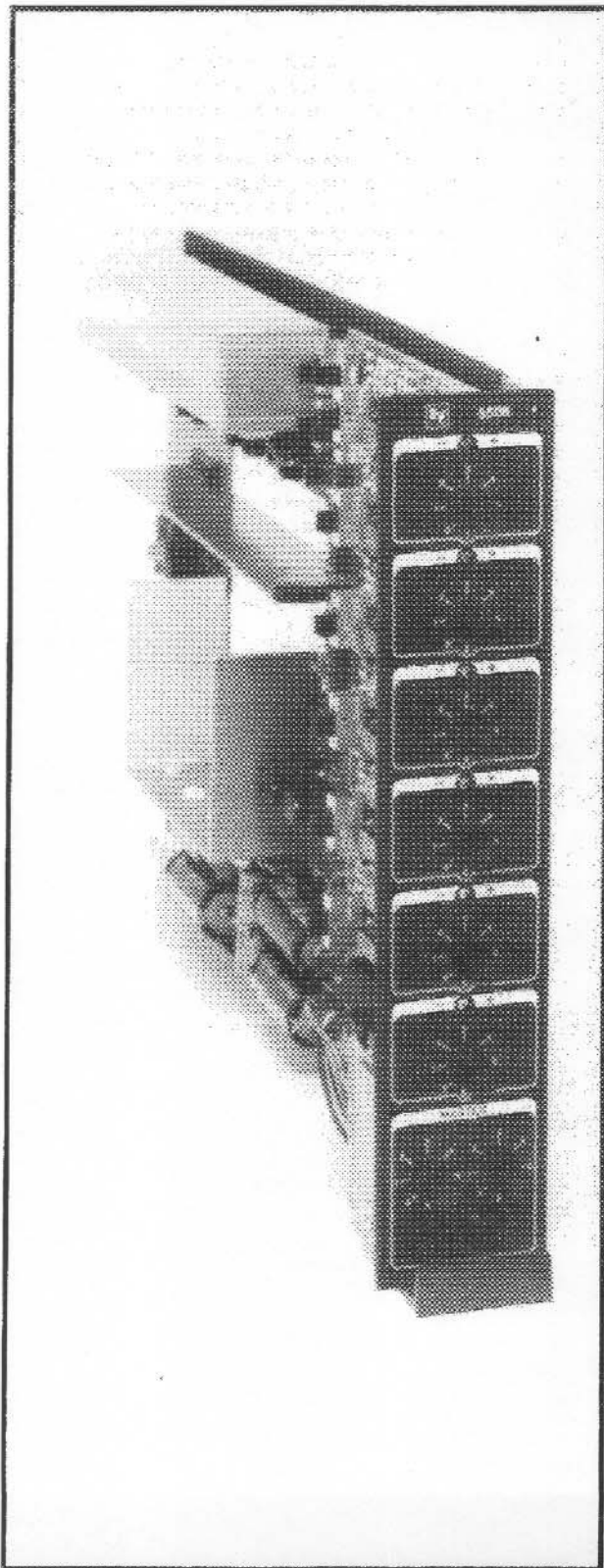

- 6 low-Z mic inputs transformer balanced
- 2 mic inputs switchable to accept line level
- 2 separate mix busses (mix buss A, buss B)
- Each input assignable to either or both mix busses
- Full remote control on each input and output
- 40 dB gain trim pad on each input
- 20 dB switchable pad on each input
- Phantom power available on each input
- Precedence control on each input
- Switchable 30 dB/octave low frequency cutoff filter on each input
- Buffered tape outputs for each mix buss
- Direct signal output (prefader) on each input
- Singal output indicators
- Front panel audio test points
- Optional security cover available

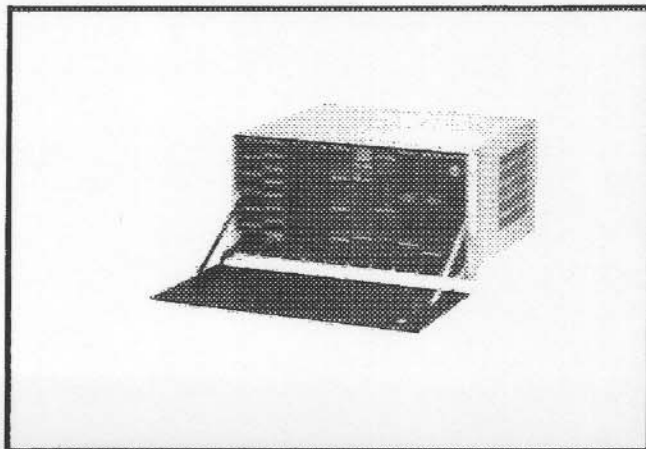



# 5506 6x2 Mixer

The Electro-Voice Model 5506 is a 6-input, 2-output microphone mixer designed for use with the Electro-Voice 5000 modular sound system. The 5506 has full remote capability on all inputs and outputs. The input/output architecture and remote control features of the 5506 combine to make it one of the most flexible professional mixers available for use in sound reinforcement systems.

Each microphone input has three levels of remote control, a gain trim potentiometer, precedence control, switchable 20 dB pad, phantom powering (available), and a 5-pole switchable high pass filter to reduce proximity effect and "P-popping." Each microphone input may be assigned to either, or both of the output busses. Two of the microphone inputs are switchable to accept line levels.

A buffered tape recorder output is available from each of the two mix busses. Access to the mix busses is available for stacking of additional mixers. Gain on all inputs and outputs can be remotely controlled. The 2 output sections are remotely switchable to either mix buss or an external source.

The 5506 has three levels of remote control: front panel remote, temporary remote, and permanent remote. The volume controls on the front panel of the 5506 act as remote controlled attenuators in each channel, located in the 5506 module. These controls constitute the first level of remote control. Front panel controls may be set for normal sound system operation and then locked securely behind the front panel cover of the model 5001 mainframe.

The front panel controls will be automatically overridden any time the second level of remote control is plugged into the system. The second level of remote control consists of a standard audio taper potentiometer connected between ground and a terminal on the rear of the 5506. For special events, provisions for sound system remote control capability can be accomplished by installing a remote control connector at a convenient location, such as at the rear of the auditorium. For special events a remote mixing board is plugged into the remote control connector. When the remote mixing board is plugged into the remote connector, the front panel controls of the 5506 automatically relinquish control to the remote mixer. At the conclusion of the special event, the mixer may be unplugged from the connector and the sound system will return to the previously established settings.

The third level of remote operation is the permanent remote. In this level of remote, the front panel controls may be disabled by clipping the appropriate jumper on the 5506 printed circuit board. After the front panel controls are disabled, they may be replaced by a remotely located audio taper potentiometer and a diode. Simple stated, we are removing the front panel control and placing it in a remote location on a permanent basis. As with the front panel remote control, permanent remote control can be overridden by installing a temporary remote control.

In summary, the 5506 will automatically switch between permanent remote and temporary remote. All remote control lines operate on a dc voltage and are immune to extraneous noise. The remote control lines may be run up to several thousand feet in length.

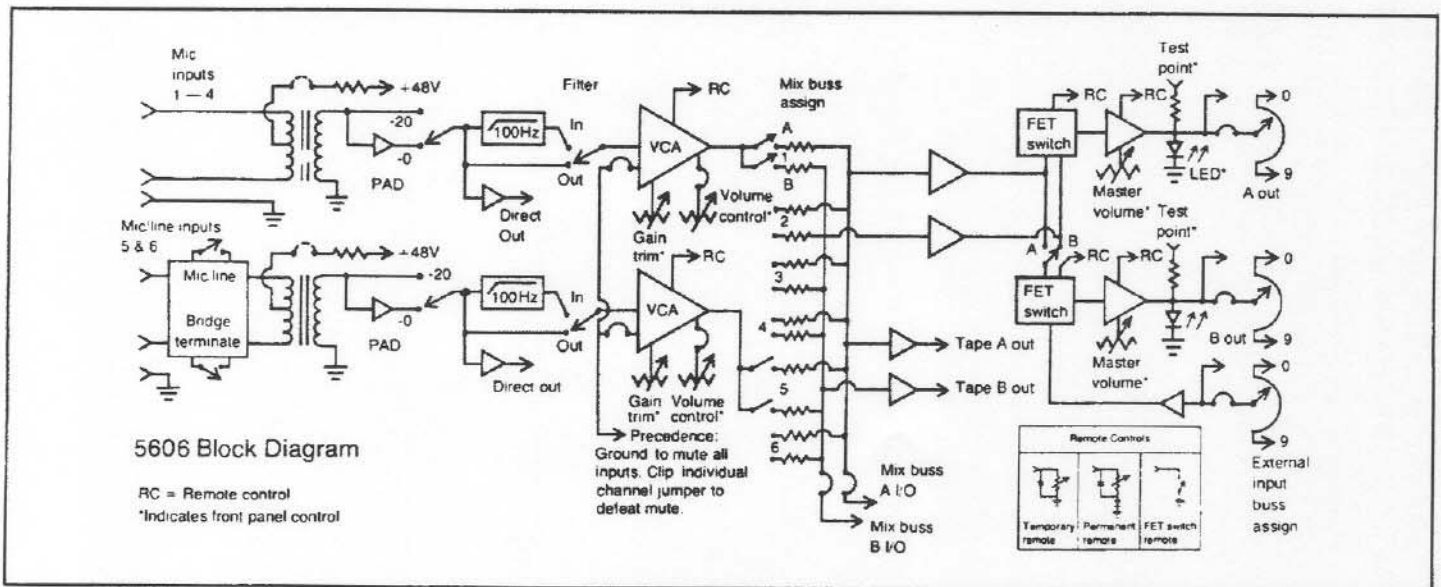

### 5506 Spec Briefs

Microphone input impedance: 150-600 ohms  
Line input impedance: 600 ohms terminated  
33,000 ohms bridged  
Input noise: -125 dB 35 kHz bandwidth  
Frequency response: 20 Hz-20 kHz +.5 dB  
Output impedance: 600 ohms or greater  
Output level: 18 dBm

THD: .08% max  
.01% typical  
High pass filters: -3 dB@135 Hz  
-40 dB@60 Hz  
Size: 8.5x14.2x1.7 inches  
Weight: 2 lb, 14 oz.

**For Warranty and Service information consult the Owner's Manual.**

**Electro-Voice, Inc.**

a Mark IV company  
600 Cecil Street  
Buchanan, MI 49107

(616) 695-6831 FAX (616) 695-1304



## 5702 Compressor/Limiter

## 5000 Modular System

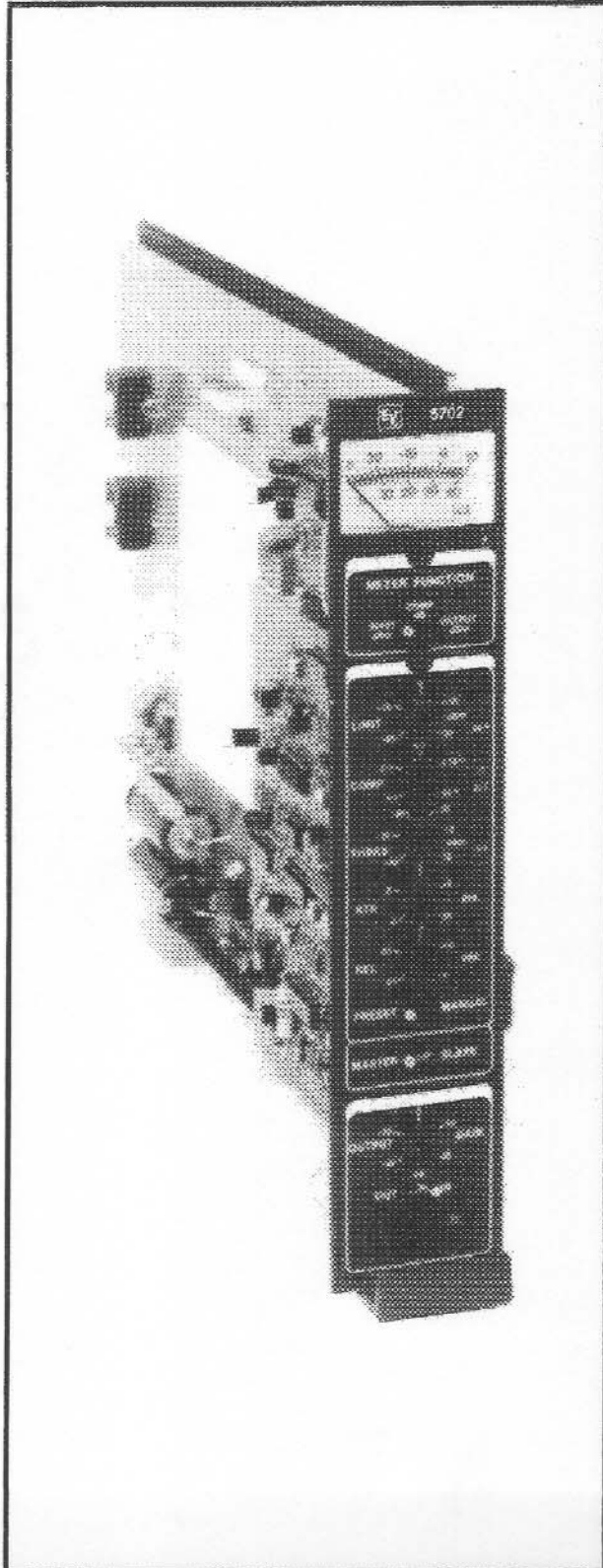

- Separate limiter and compressor
- Front panel meter
- Adjustable meter offset
- Utilizes "soft knee" compression
- Automatic fail-safe bypass
- Gated mode, switchable
- Master/slave for combining compressors
- LED threshold indicators
- Adjustable compression ratio
- Adjustable attack and release time
- Adjustable limiter and compressor thresholds
- Preset or manual operation
- Front panel test point

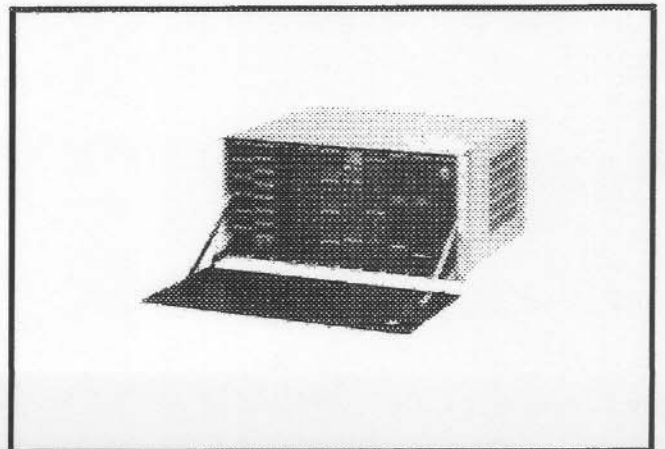





## 5702 Compressor/Limiter

The 5702 is a professional compressor/limiter designed for use in the most demanding application. The 5702 has many features specifically designed for sound reinforcement and teleconference applications.

It may be used to protect loudspeakers and amplifiers from overloads, or in paging system to accommodate a wide variety of announcers. Teleconference systems are made more pleasant with the use of the 5702 in the gated mode. Announcements may be made to sound louder. The 5702 may be used to match the large dynamic range of live material to the more restricted dynamic range of electronic systems.

The 5702 employs a "Soft Knee" compression curve to provide smooth, inaudible compression. Compression does not abruptly occur at the threshold setting, but occurs over a transition range or "window" of 8 dB. The compression ratio is gradually increased over this 8-dB window from linear, or 1:1, to the desired compression ratio.

Another important feature of the 5702 is its quasi-RMS detector. The detector monitors the audio signal and tells the voltage controlled attenuator (VCA) when gain reduction (compression) is required. Because normal program material is not sinusoidal but complex in waveform, it is important that the detector is not fooled. The quasi-RMS is not fooled by complex waveforms, but detects the true power of the waveform. This detector, coupled with the "Soft Knee" compression curve, provides accurate, inaudible compression.

The 5702 has a separate limiter and compressor. The limiter has a compression ratio of 1:∞ and is adjustable over an input range of -20 dBm to +20 dBm. A red LED on the front panel is illuminated when the limiter is achieved.

The compressor section of the 5702 has many front panel controls including: COMPRESSION RATIO, THRESHOLD LEVEL, ATTACK TIME, RELEASE TIME, PRESET/MANUAL and MASTER-SLAVE operation. The compression ratio is adjustable from 1:1 (no compression) to 1:∞ or infinite compression. The COMPRESSION THRESHOLD control is adjustable from -40 dBm to +10 dBm input. The attack and release times are also adjustable when the PRESET/MANUAL switch is set to manual. When this switch is in the PRESET position, the attack and release times are preset to nominally ideal settings for most applications.

The compressor also has one internal control, the NORMAL/GATE mode switch. In the gated mode, the compressor acts normally, with one exception. When the signal to the compressor is discontinued, the

compressor remains gated on, at the present level of compression, awaiting the next signal. In the non-gated or NORMAL mode, the level of compression would return to zero. The gated mode is a benefit in paging and teleconference applications. For example, a normal compressor attacks and compresses a signal that is too loud. While compressing this signal, it also compresses the background noise. When compression is no longer required, the background noise returns or increases to its normal level. When someone is talking there are natural pauses between words and phrases. It is during these pauses that the compressor restores the normal level of background noise causing an audible pumping effect. The gated compressor, in contrast, gates on and holds the last level of compression during these pauses, thus keeping the background noise compressed as well. When speech is resumed the gate is turned off and the compressor as well. When speech is resumed the gate is turned off and the compressor is allowed to function normally.

The 5702 has a MASTER/SLAVE switch that allows 5702's to be ganged together for multiple channel operation. The detectors of all 5702's are summed together and then routed to the VCA's of the ganged 5702's. This prevents a shift in the stereo image due to one channel compressing more than the other channel.

A front panel meter and meter function switch allow the monitoring of input and output levels in dBm and the amount of compression in dB. A meter trim control allows the meter zero reference to be offset. The meter employs backlit illumination for easy viewing.

The LED's on the front panel provide compression status indication. A green LED indicates when the compression ratio is 1:1. The yellow LED indicates a compression ratio of 1:C, the ratio set by the compression control. The red LED indicates a 1:∞ ratio or activation of the limiter. A yellow LED located beside the front panel test point indicates signal presence on the output of the module.

An output level control and IN/OUT switch round out the controls of the 5702. The output level control is adjustable from -20 to +20 dBm. The 5702 may be bypassed by placing the IN/OUT switch in the OUT position. This provides a direct bypass feature. In the event of an on-board power supply failure the 5702 is automatically bypassed. The IN/OUT switch may also be remotely activated.

The feature and operation characteristics of the 5702 have been optimized for sound reinforcement application.

### 5702 Spec Briefs

Frequency response:  $\pm 5$  dB 20 Hz to 20 kHz  
Distortion (THD) in compression or limit  
+10 dBm input, 0 dBm output:  
less than .05% @ 1 kHz  
.05% @ 100 Hz  
Compression ratio: adjustable 1:1 to 1:∞  
Threshold: adjustable -40 to +10 dBm  
Attack time: adjustable .2 to 20 milliseconds  
Release time: adjustable  
.01 to 1 sec in normal mode  
.1 to 10 sec in gated mode

Limiter: adjustable -20 to +20 dBm  
Input impedance: 10,000 ohms  
Maximum input level: +22 dBm  
Output level: maximum +18 dBm  
Meter range: 40 dB  
Meter offset: adjustable -10 to +10 dB  
Size: 8.5x4.2x1.7 inches

**For Warranty and Service information consult the Owner's Manual.**

Form 2875 • ©Electro-Voice, Inc. 1989 • Litho in U.S.A.

## Electro-Voice, Inc.

a Mark IV company

600 Cecil Street

Buchanan, MI 49107

(616) 695-6831 FAX (616) 695-1304





# 5805A/5806 Amplifier Combination

# 5000 Modular System

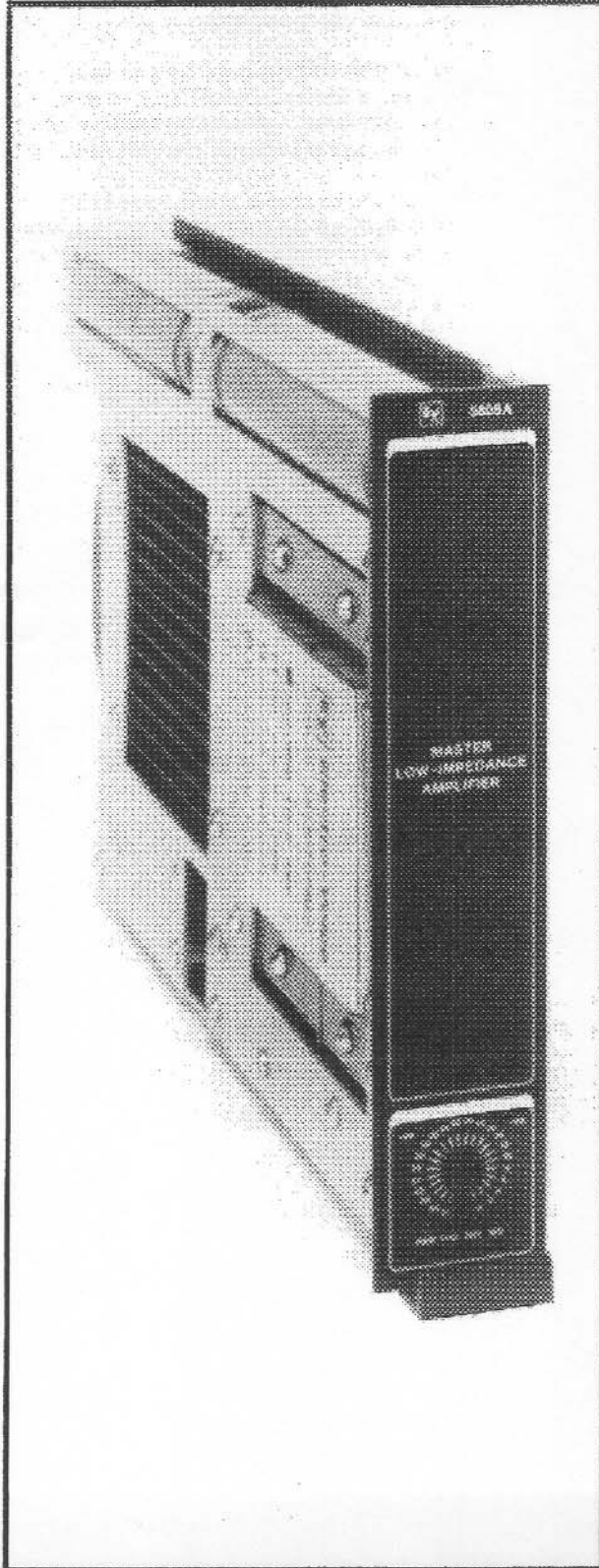

- Independent power supply
- SOA protection
- DC crowbar protection
- LED status indicators
- Digital I/O ports for remote monitoring
- Audio test point
- May be paralleled or bridged with other amplifiers
- Thermal overload protection

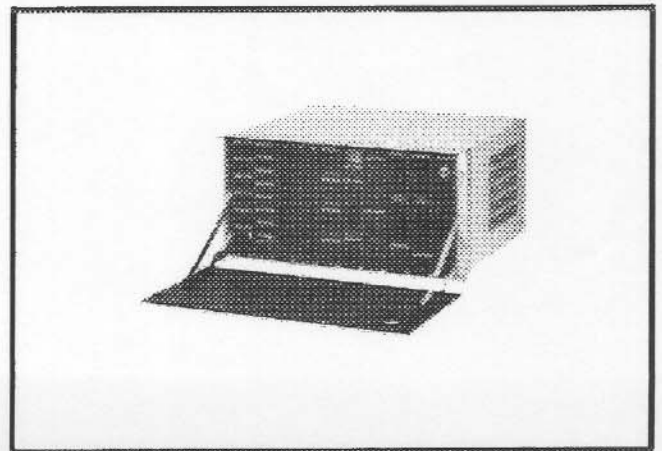



# 5805A/5806 Amplifier Combination

As part of the EV 5000 Modular Sound System, the model 5805A low impedance master amplifier introduces a new concept in power amplification. The 5805A is a self-contained, 100-watt, power amplifier module designed to drive low impedance loads (4 ohm, 8 ohm). The 5805A has many innovative features including the ability to drive a companion slave amplifier in parallel or another 5805A master amplifier in a bridge configuration. The bridge and parallel configurations allow the amplifier modules to be combined to drive a wide variety of low impedance loads at various power levels. Other innovative features include front panel LED status indicators, audio test points, and amplifier I/O ports to allow remote computer monitoring of the amplifier's operational status. The front panel LED's display amplifier operational parameters such as ac power, distortion in excess of 1%, amplifier in stand-by mode due to manual of thermal triggering, and the presence of an audio signal at the output of the amplifier. The audio test point provides convenient front panel access of the amplifier's output for monitoring purposes. The 5805A exhibits excellent frequency response, slew rate, low noise and the low distortion typical of a state-of-the-art design. For more detailed amplifier specifications, see the SPEC BRIEFS listed below.

One of the most important design goals of a power amplifier should be reliability. The 5805A is reliable. It was designed carefully and conservatively so that it would be.

5805A reliability is assured thermal overload protection, safe operating area protection, and a two-speed, thermostatically controlled, forced-air cooling

system. Every 5805A is thoroughly tested and burned in for 72 hours before it leaves the factory. As a final precaution, in the unlikely event that the 5805A should fail, a dc crowbar protection circuit will prevent damage to loudspeakers.

Another strength of the 5805A is its onboard power supply. Since it has its own power supply, a power supply failure cannot affect other amplifiers or signal processing modules. And since the system is modular, a defective amplifier can be quickly and easily changed without shutting down the entire system.

The 5806 low impedance slave is a companion amplifier for the 5805A master. The 5806 slave is a duplication of the 5805A master's on-board power supply and audio output sections. The 5806 slave provides an economical approach to increasing the power applied to various loads. When the slave is plugged into a mainframe slot directly to the right of a master amplifier, all internal connections are automatically made between the master and slave need to be paralleled on the rear of the mainframe. The 5806 has two LED status indicators, one for ac power and the other for signal output indication.

A master may be paralleled with a slave to increase power output into a lower impedance load. Also, masters may be bridged together to provide increased power into a higher impedance load. Combinations of masters paralleled with slaves and then bridged with other masters and slaves can also be easily done to meet virtually any system demand. The diagram below shows several combinations of masters and slaves.

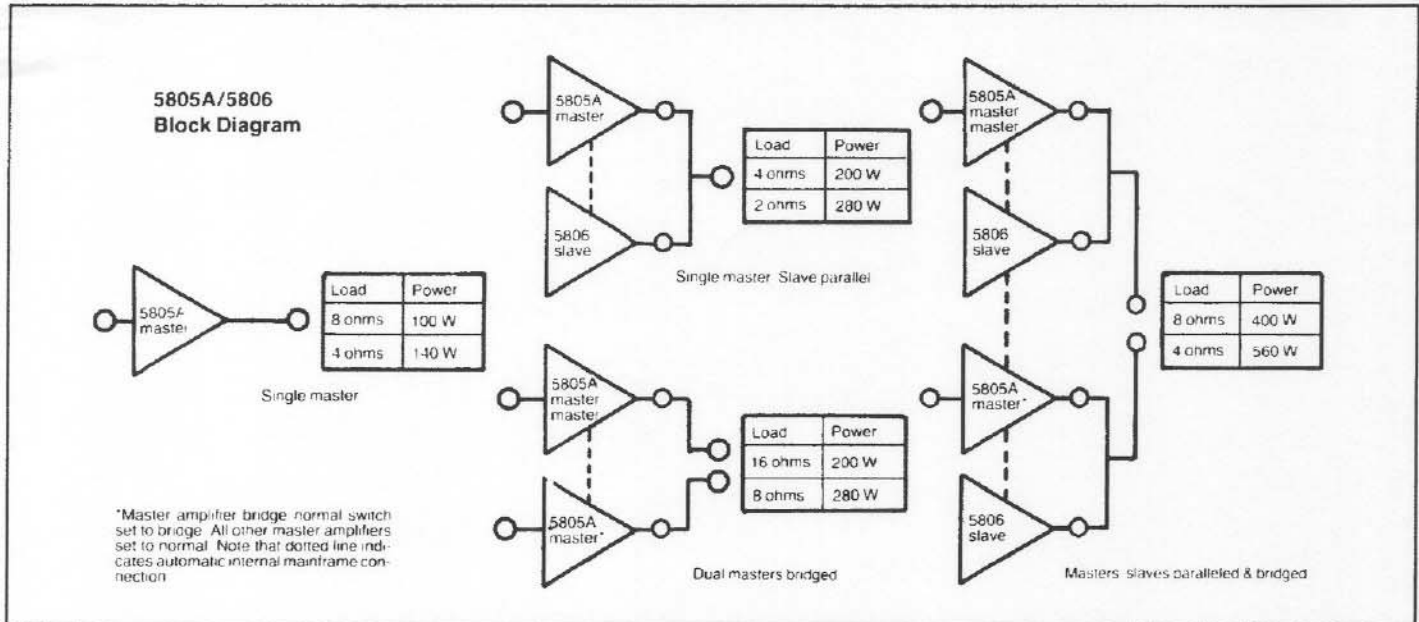

### 5805A/5806 Spec Briefs

Power output: continuous average sine wave power into 8 ohms is 100 watts, into 4 ohms is 140 watts

Frequency response: +0 -1 dB  
20 Hz-20 kHz

THD at rated output (80 kHz bandwidth):

100 watts at 1 kHz = .025% typical  
(.05% maximum)

100 watts at 20 kHz = .08% typical  
(.15% maximum)

20 watts at 2 kHz = .05% maximum

10 watts at 20 kHz = .15 maximum  
Hum and noise: -105 dBA below maximum  
output power

Damping factor: greater than 200 at 8 ohms  
Slew rate: greater than 20 volts  
per microsecond

Input sensitivity: .775 V for maximum  
power output

Input impedance: 10,000 ohms  
Size: 8.5x4.2x1.7 inches

Weight: 9 lbs, 8 oz.

**Electro-Voice, Inc.**

a Mark IV company

600 Cecil Street

Buchanan, MI 49107

(616) 695-6831 FAX (616) 695-1304

**For Warranty and Service information consult the Owner's Manual.**

Form 2881 • ©Electro-Voice, Inc. 1989 • Litho in U.S.A.



## 5807A/5808 Amplifier Combination

## 5000 Modular System

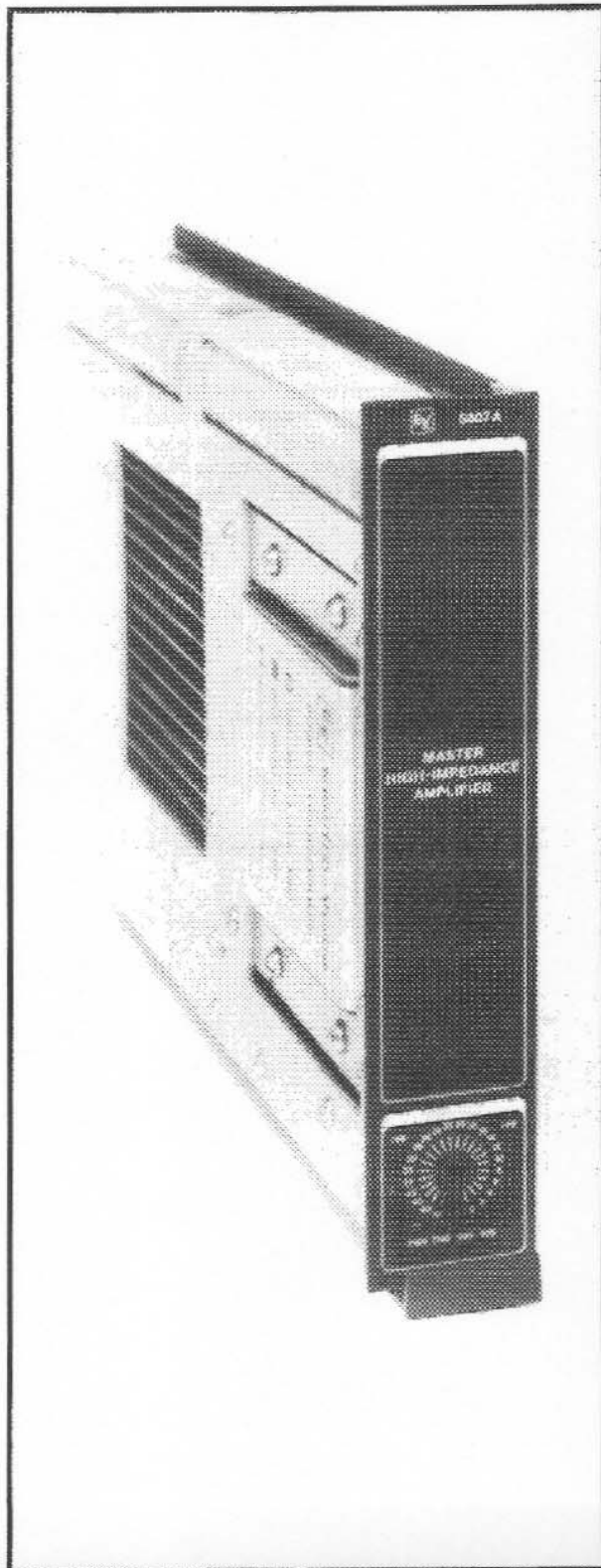

- 100 watts at 70.7 volts
- Independent power supply
- SOA protection
- DC crowbar protection
- LED status indicators
- Digital I/O ports for remote monitoring
- Audio test point
- May be paralleled or bridged with other amplifiers
- Thermal overload protection
- Stepped attenuator

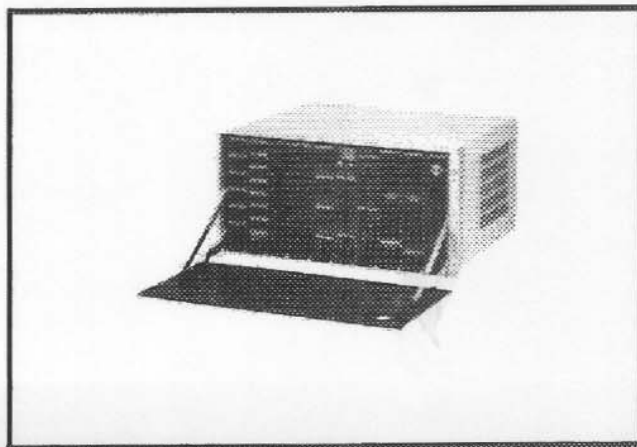



# 5807A/5808 Amplifier Combination

As part of the 5000 Modular Sound System, the model 5807A high impedance master amplifier introduces a new concept in power amplification. The 5807A is a self-contained, 100-watt, power amplifier module designed to drive high impedance loads at 70.7 volts.

The 5807A has many innovative features including the ability to drive up to 8 slave amplifiers in parallel for up to 900 watts of output power at 70.7 volts or to drive another 5807A master amplifier in a bridge configuration for 140-volt output operation. Up to 800 watts of output power at 140 volts may be realized. The diagram shows several combinations of masters and slaves.

Other innovative features include front panel LED status indicators, audio test points, and amplifier I/O ports to allow remote computer monitoring of the amplifiers operational status. The front panel LED's display amplifier operational parameters such as ac power, distortion in excess of 1%, amplifier in stand-by mode due to manual or thermal triggering, and the presence of an audio signal at the output of the amplifier. The audio test point provides convenient front panel access to the amplifiers output for monitoring purposes. The 5807A exhibits excellent frequency response, slew rate, low noise and the low distortion typical of a state-of-the-art design. For detailed amplifier specifications, see the SPEC BRIEFS listed below.

One of the most important design goals of a power amplifier should be reliability. The 5807A is reliable. It was designed carefully and conservatively so that it would be.

5807A reliability assured by thermal overload protection, safe operating area protection, and a two-speed, thermostatically controlled, forced air cooling system. Every 5807A is thoroughly tested and burned in for 72 hours before it leaves the factory. As a final precaution, in the unlikely event that the 5807A should fail, a dc crowbar protection circuit will prevent damage to loudspeakers.

Another strength of the 5807A is its onboard power supply. Since it has its own power supply, a power supply failure cannot affect other amplifiers or signal processing modules. And since the system is modular, a defective amplifier can be quickly and easily changed without shutting down the entire system.

The 5808 high-impedance slave is a companion amplifier for the 5807A master. The 5808 slave is a duplication of the 5807A master's on-board power supply and audio output sections. The 5808 slave provides an economical approach to increasing the power applied to various loads. When the slave is plugged into a mainframe slot directly to the right of a master amplifier, all internal connections are automatically made between the master and the slave. Only the outputs of the master and slave need to be paralleled on the rear of the mainframe. The 5808 has two LED status indicators, one for ac power and the other for signal output indication.

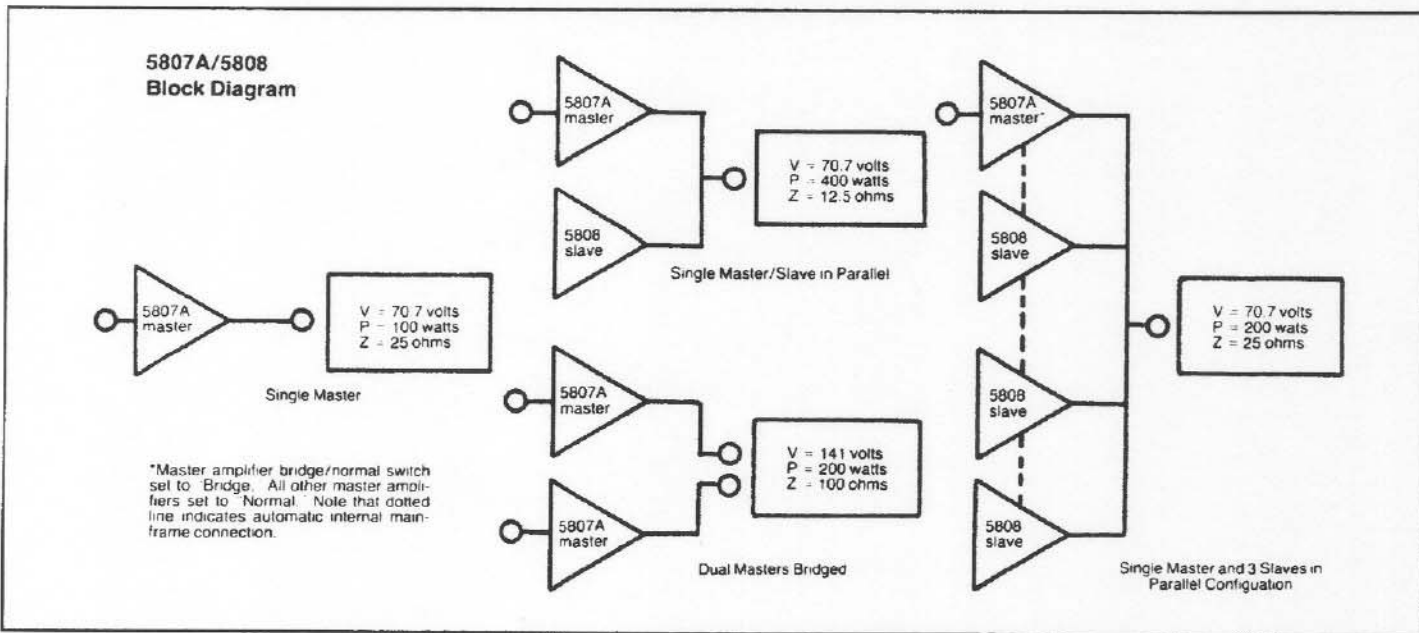

### 5807A/5808 Spec Briefs

Power output: continuous average sine wave power into 50 ohms is 100 watts (70.7 volts).  
 Frequency response: +0, +1 dB  
 20 Hz to 20 kHz  
 THD at rated output (80 kHz bandwidth):  
 100 watts at 1 kHz = .025% typical (.05% maximum)  
 100 watts at 20 kHz = .09% typical (.15% maximum)

Hum & noise: -105 dBA below maximum output power  
 Damping factor: greater than 200  
 Slew rate: greater than 20 volts per microsecond  
 Input sensitivity: .775V for maximum power output  
 Size: 8.5x4.2x1.7 inches  
 Weight: 9 lb, 8 oz.

For Warranty and Service Information consult the Owner's Manual.

Form 2876 • ©Electro-Voice, Inc. 1989 • Litho in U.S.A.

**Electro-Voice, Inc.**

a Mark IV company  
 600 Cecil Street  
 Buchanan, MI 49107  
 (616) 695-6831 FAX (616) 695-1304





**5825  
Dual 50-Watt Low-Impedance  
Amplifiers**

**5000  
Modular System**

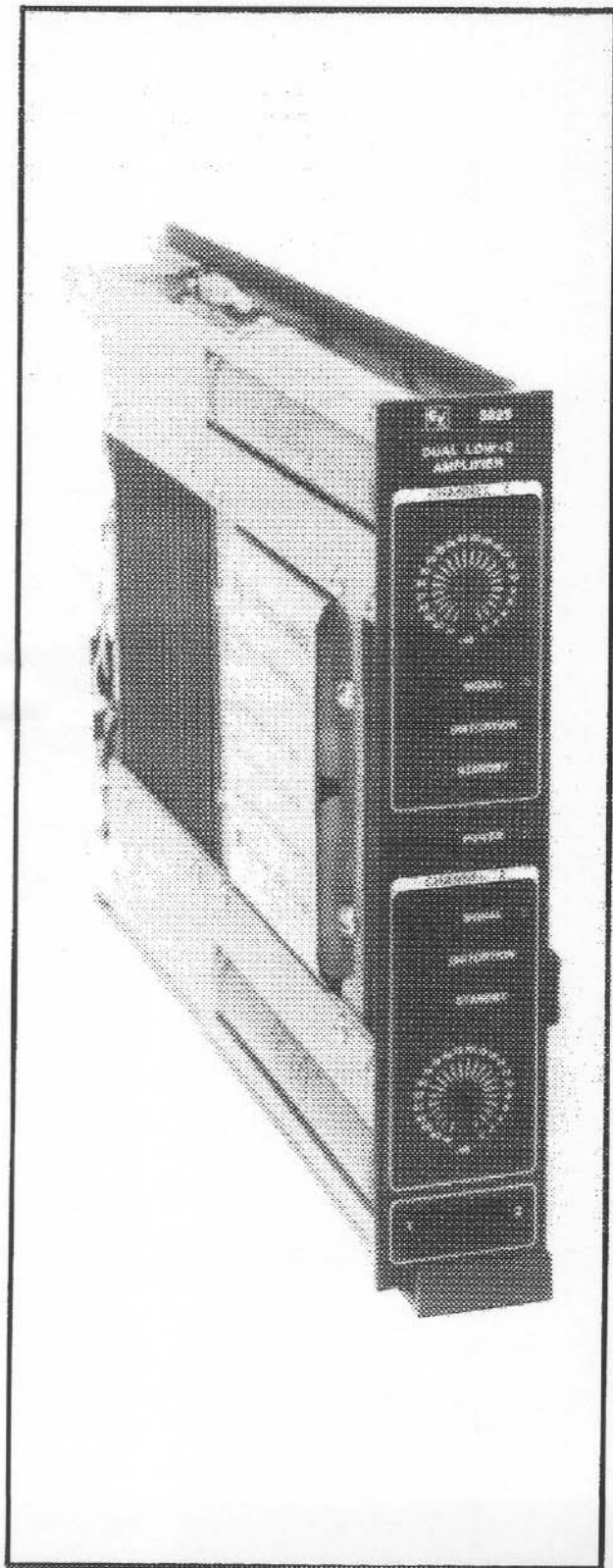

- Dual 50-watt low-impedance amplifiers
- Stepped attenuators
- SOA protection
- Load protection for dc output
- Independent module power supply
- I/O port for remote monitoring
- Front panel LED's may be removed
- Thermal overload protection
- Front panel test point

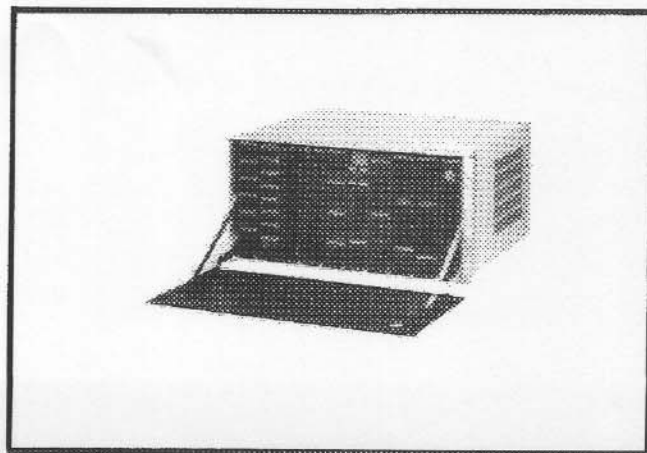



5825

## Dual 50-Watt Low-Impedance Amplifiers

The 5825 is a single 5000 system module containing two low-impedance 50-watt amplifiers. Similar to all other 5000 amplifier modules, the 5825 has its own on-board power supply. Requiring only ac power from the motherboard, the 5825 is an independent, dual 50-watt amplifier module. The two amplifiers on the 5825 are completely independent from each other, only sharing the common on-board power supply.

The two audio inputs may be accessed via two audio bus assign switches receiving audio signals from the 5001 motherboard. The inputs are also directly accessible via a terminal block (model TB40) mounted on the rear of the mainframe. One output uses the terminal block designated for amplifier output. The second output uses the TB40 mounted behind the amplifier. Various other signal and control lines also appear on the TB40.

One of the most important design goals for a power amplifier should be reliability. This was the major design goal for the 5825. A conservative approach to circuit design, coupled with the use of overrated parts provide a very reliable amplifier. Reliability is further enhanced by thermal overload protection, safe operating area protection and a two-speed thermostatically controlled, forced-air cooling system. Every 5825 is thoroughly tested and burned-in under load for 72 hours before it leaves the factory.

As a final precaution, the 5825 has a built-in protection feature that prevents dc from ever reaching the speakers in the event of output device failure.

The audio quality of the 5825 is up to the most demanding of professional applications. The 5825 exhibits excellent frequency response, slew rate, low noise and low distortion — typical of state-of-the-art design. For more detailed specifications, see the spec briefs listed below.

A 22-position 2-dB-per-step attenuator is used on each of the two inputs. This attenuator is not a detented volume control, but a 22-position switch connected to a laser-trimmed resistor array. Accuracy  $\pm .5$  dB per step. The stepped attenuator makes relative level adjustment of speaker clusters a snap. The stepped attenuator also allows accurate repeatable setting of amplifier levels.

There are seven LED's on the front panel. A green LED labeled POWER is shared by both amplifiers and indicates the amplifier is receiving ac power. Each channel also has a yellow LED labeled SIGNAL and two red LED's labeled DISTORTION and STANDBY.

The LED labeled SIGNAL is illuminated when there is a signal on the output of the amplifier and functions as a signal presence indicator. The DISTORTION LED functions as a clip indicator and is illuminated when the total harmonic distortion of the amplifier exceeds 1%.

The STANDBY LED is illuminated when the amplifier has been placed into the standby mode due to manual, or internal thermal triggering. In standby mode, all dc bias from the amplifier is removed and the amplifier will not pass program material.

The 5825 has provisions for remote monitoring of its performance status. Signal presence, distortion, standby, high-speed fan request, and power supply failure may be remotely monitored. These monitor output ports are located on the terminal block (TB40) located behind the amplifier.

The power supply failure and standby status lines are also routed to a motherboard summary fault bus. The output of this summary bus appears on the 5001 mainframe AUX PWR connector. A summary distortion fault line is also routed to AUX PWR connector. All 5825 amplifiers may be monitored individually via a TB40 or as a mainframe group via the AUX PWR connector.

Another remote feature of the 5825 is the ability to place the amplifier in standby. While in standby the amplifier is muted and will not pass an audio signal. A simple contact closure is all that is required to place an amplifier in standby. The standby feature provides added versatility in system design requiring zone only switching.

The amplifier will automatically be placed in standby if the heatsink temperature rises above a certain point. As soon as the heatsink cools sufficiently, the amplifier will automatically be placed back into operation.

The 5825 has many outstanding features: stepped attenuators, test points, front panel LED's, remote monitoring capability, and excellent performance. The 5825 is economical—economical in price, cost of installation, cost of maintenance, and cost of space required. Up to nine 5825 amplifiers may be placed in one 5001 mainframe providing 18 channels of amplification in less than 9 inches of vertical rack space. The 5825 is a powerful and versatile addition to the 5000 modular sound system.



## 5934 Room Combiner

## 5000 Modular System

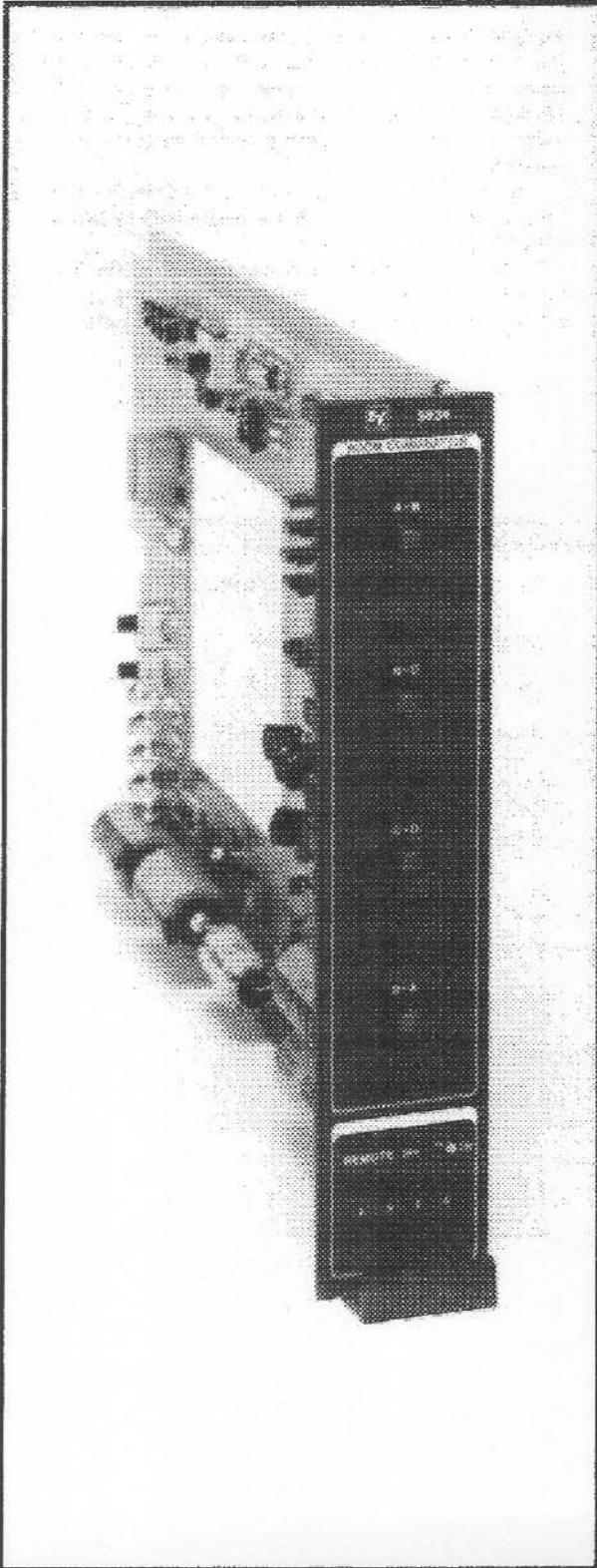

- Combines up to 4 rooms
- Front panel and remote indication of status
- Buffered tape outputs
- Selectable 0 or  $-3$  dB attenuation per doubling of rooms
- Will support multiple remote locations

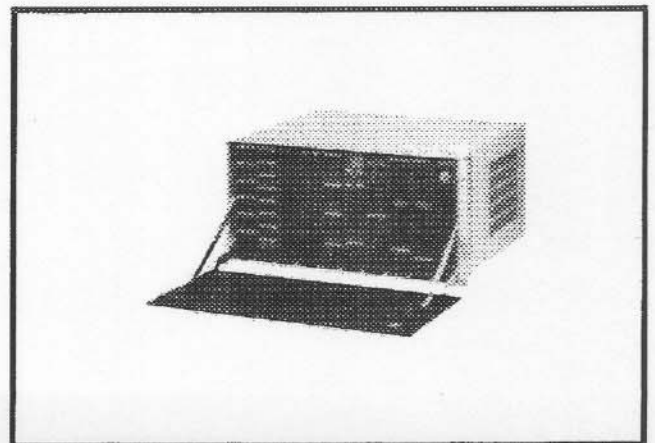



# 5934 Room Combiner

The 5934 is designed to be used in conjunction with the 5505 and 5506 mixers. The 5502, 5503 and 5504 mixers should not use the 5934 but should use their built-in room combining features.

The 5934 combines the outputs of up to four mixers. The combining process is accomplished by "shorting" the outputs of the mixers together. The mixers require a slight modification before they can be used with the 5934. The modification requires that a 600-ohm resistor be placed in series with the output of the mixer. This is easily accomplished by replacing a wire jumper on the printed circuit board with the supplied resistor.

The outputs of the mixers are "shorted" together by FET switches. Normally, when two mixers of the same output impedance are combined, their output level will drop by 6 dB. If four mixers are combined, their output level will drop by another 6 dB, or a total of 12 dB. However, the 5934 has a special circuit to prevent a drop in output level when mixers are combined. This circuit is switchable to provide a 0.0-dB drop per doubling or 3-dB drop per doubling, following the attenuation for NOM (Number of Open Microphones).

There are four, illuminated, momentary switches on the front panel of the 5934. These four switches control which busses on the 5001 Mainframe are "shorted" together. These switches may be duplicated in remote location(s). A five wire, low voltage dc control line is all that is required. The remote switches may be either the momentary or toggle type. A toggle switch on the 5934 front panel provides the ability to disable all remote switches.

The 5934 can combine busses 1-4 or 5-8 on the 5001 Mainframe mother board. The buss assignments are determined by two slide switches on the 5394 printed circuit card.

There are four buffered tape outputs on the 5934. These tape outputs follow the combining of the rooms eg., when two rooms are combined, the two associated tape outputs are also combined.

